



Research & Development Facility
41/1854, Veekshanam Road, Near Kacheripady, Ernakulam North, Cochin -18
PH:-0484 4014004 www.neonainnovation.com

OCTOPROG User Manual

Ver 103

Contents

CHAPTER 1	Introduction.....	2
1.1	Features.....	2
1.2	Overview.....	2
1.3	Octoprog Gang Programmer Connections.....	3
CHAPTER 2	Operation.....	4
2.1	Software Installation.....	4
2.2	Driver Installation.....	4
2.3	Running Crypto+ Application	10
2.4	Download Program to target devices.....	11
2.5	LED Indications.....	12

Chapter 1

Introduction

The Octoprog Gang programmer is a RL78/R8C Family device programmer that can program up to eight identical devices at the same time. The Octoprog Gang Programmer connects to a host PC using USB and provides flexible programming options that allow the user to fully customize the process. The Octoprog gang programmer provides an economical and reliable means of programming a wide range of RL78/R8C microcontroller units (MCUs). It is designed with a versatile hardware platform to support programming of different MCUs. The Octoprog gang programmer can be used to program eight devices simultaneously by copying data held in an internal flash memory to the MCUs' internal memory.

1.1 Features

The Octoprog features include:

- Economical means of programming the internal flash memory of a wide range of RL78/R8C family of microcontroller units.
- Stand-alone programming mode of operation.
- Single +5V, 3A dc power supply requirement.
- Eight pairs of 14 pin FRC male connectors to accommodate for up to eight MCU programmer stations.
- Multicolor Status LEDs for each programming station.
- Supports encryption of hex file with a 16 digit password key.
- Supports Factory reset function

Note: Support for RL78-G10 family devices is removed from standard model of Octoprog

1.2 Overview

Octoprog software allows user to encrypt and download the hex-file from PC to Gang Programmer using USB connection. Only if the encryption key in programmer and key used for hex-file encryption matches then code will be successfully programmed. This help the user to share the hex-file (encrypted) with EMS provider as the encrypted hex file can be used only with the respective programmer. In addition to this Octoprog allows the user to set the number of targets to be programmed, once target count is reached programmer will wipe out its internal memory and won't program any further targets.

1.3 Octoprog Gang Programmer Connections

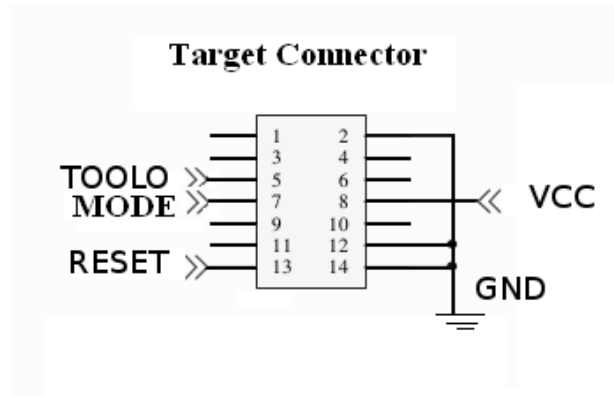

Figure 1.1

Chapter 2

Operation

This chapter explains how to use your Octoprog device in USB_MODE & PROGRAM_MODE. The only required connection for stand-alone operation is the +5V, 3A dc power connection.

2.1 Software Installation

To install Octoprog Gang Programmer software:

- Insert the Octoprog CD-ROM into the CD-ROM drive of the host computer. Click on the Setup automatically to start the installation process.
- Follow the instructions in the installation process.
- When the setup program is complete, Crypto+ icons are available in the Start menu->All programs->Crypto+.
- To start the Crypto+, click the newly created icon.

2.2 Driver Installation

To install the required driver:

- Insert the Octoprog CD-ROM into the CD-ROM drive of the host computer. Copy the Octoprog.inf file to your system.
- Press the Start Button on the programmer while connecting the Octoprog USB cable to your Programmer (This will initialize the programmer in USB_MODE, Refer section 2.3) & follow the steps below.

(Note: Octoprog is powered from USB here)

1. Right click on **my computer** & select **properties->device manager**. Right click on **OCTOPROG V100** & select **Update driver Software**

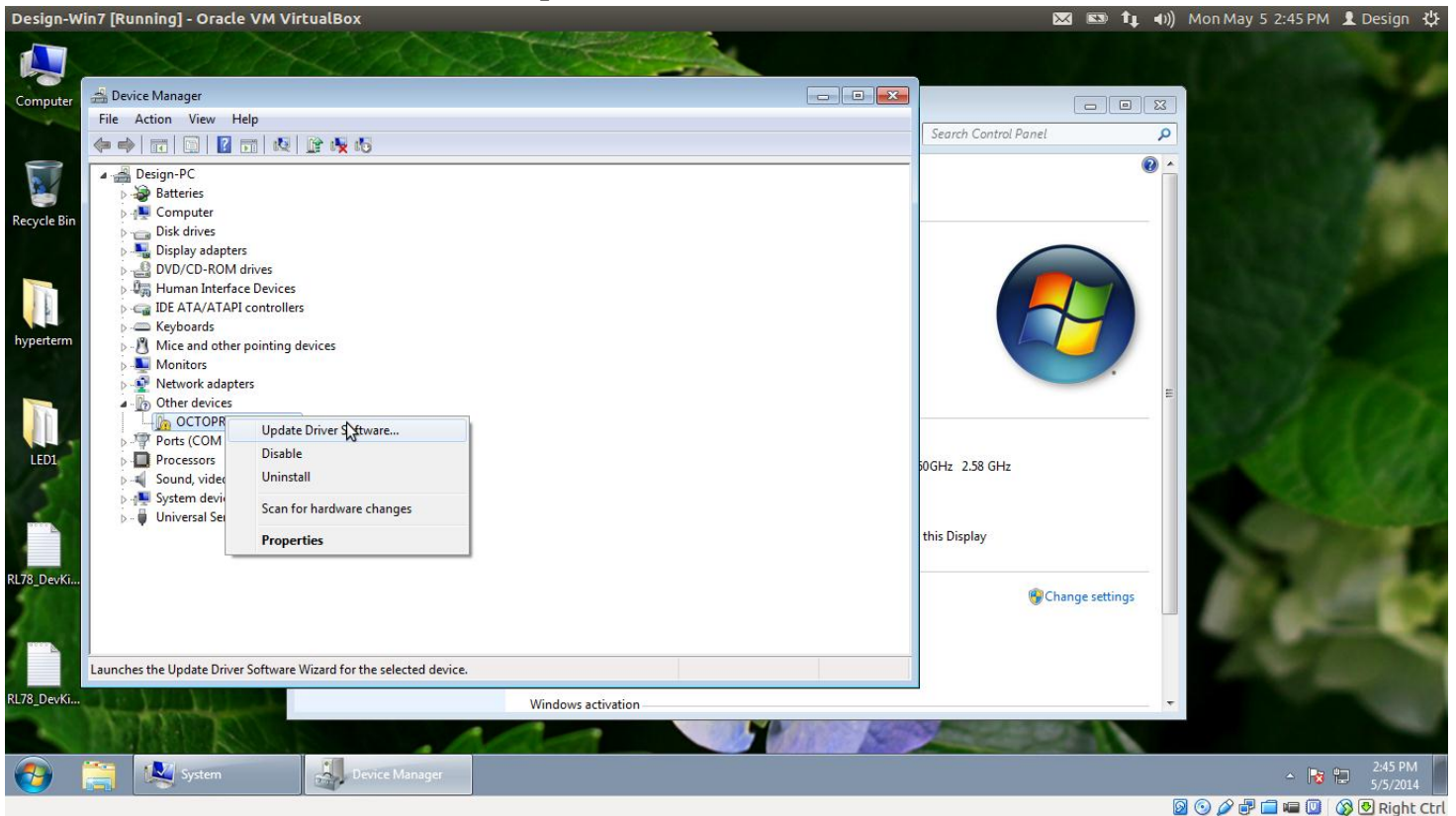

Figure 2.1

2. Select **Browse my computer for driver software**

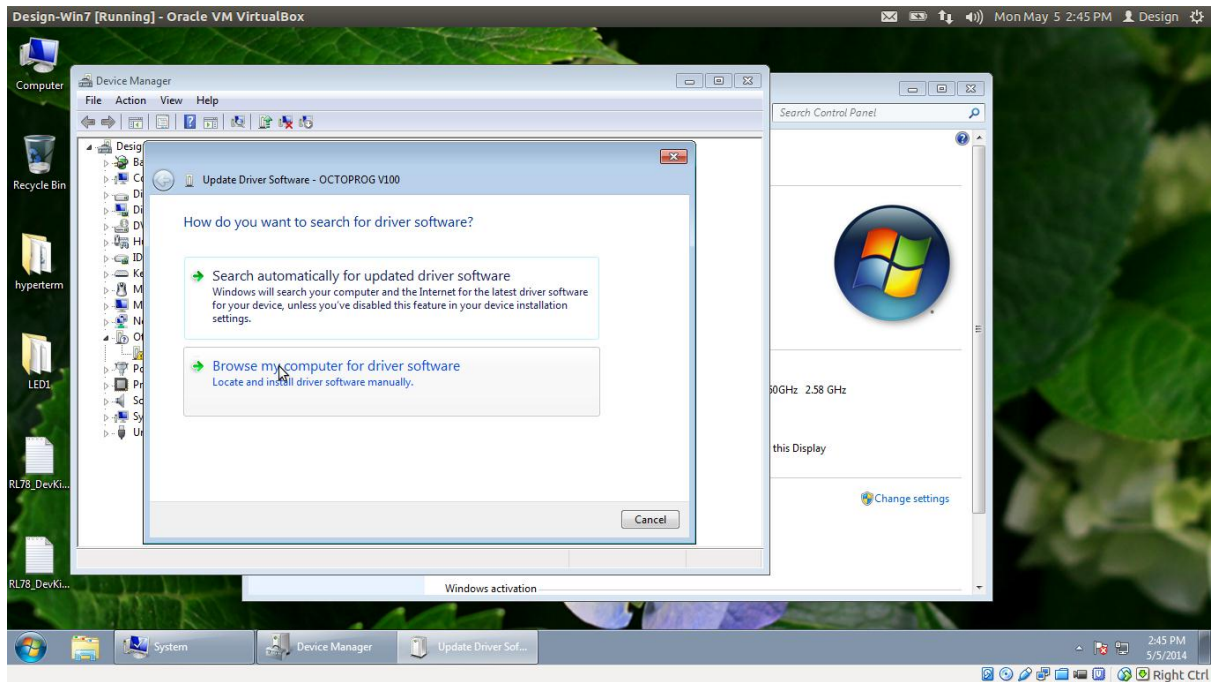

Figure 2.2

3. Select **Let me pick from a list of device drivers on my computer**

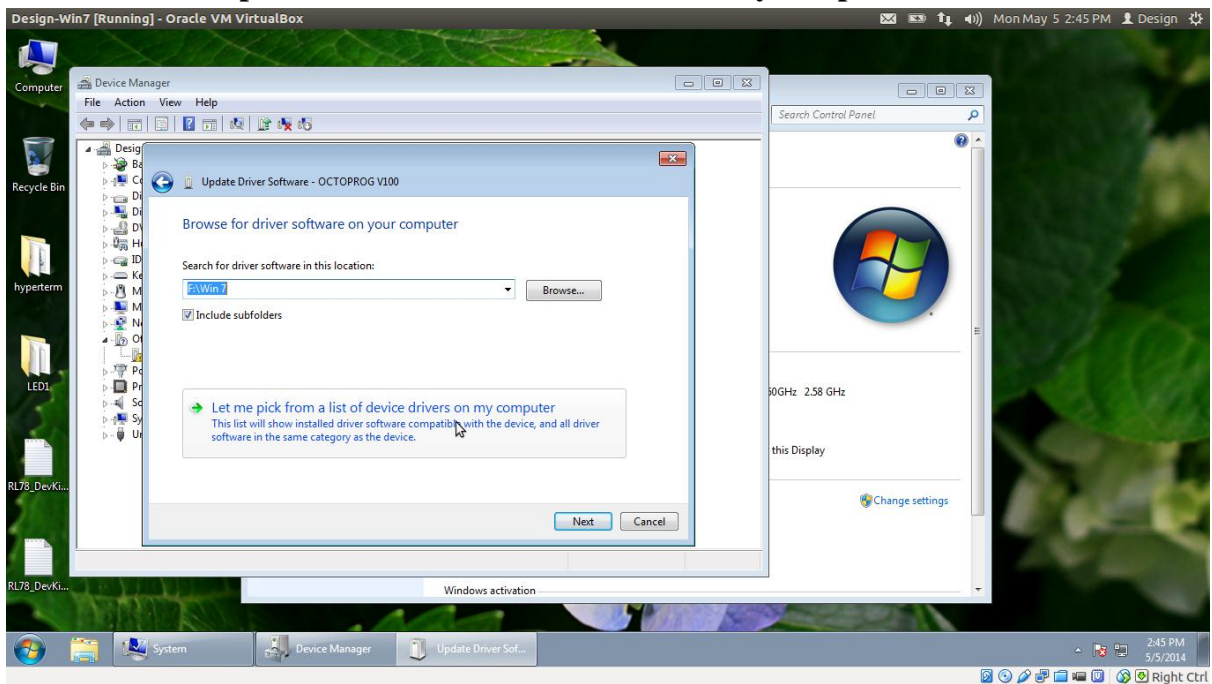

Figure 2.3

4. Select your device type from the list. Select **Show all devices** & click **next**

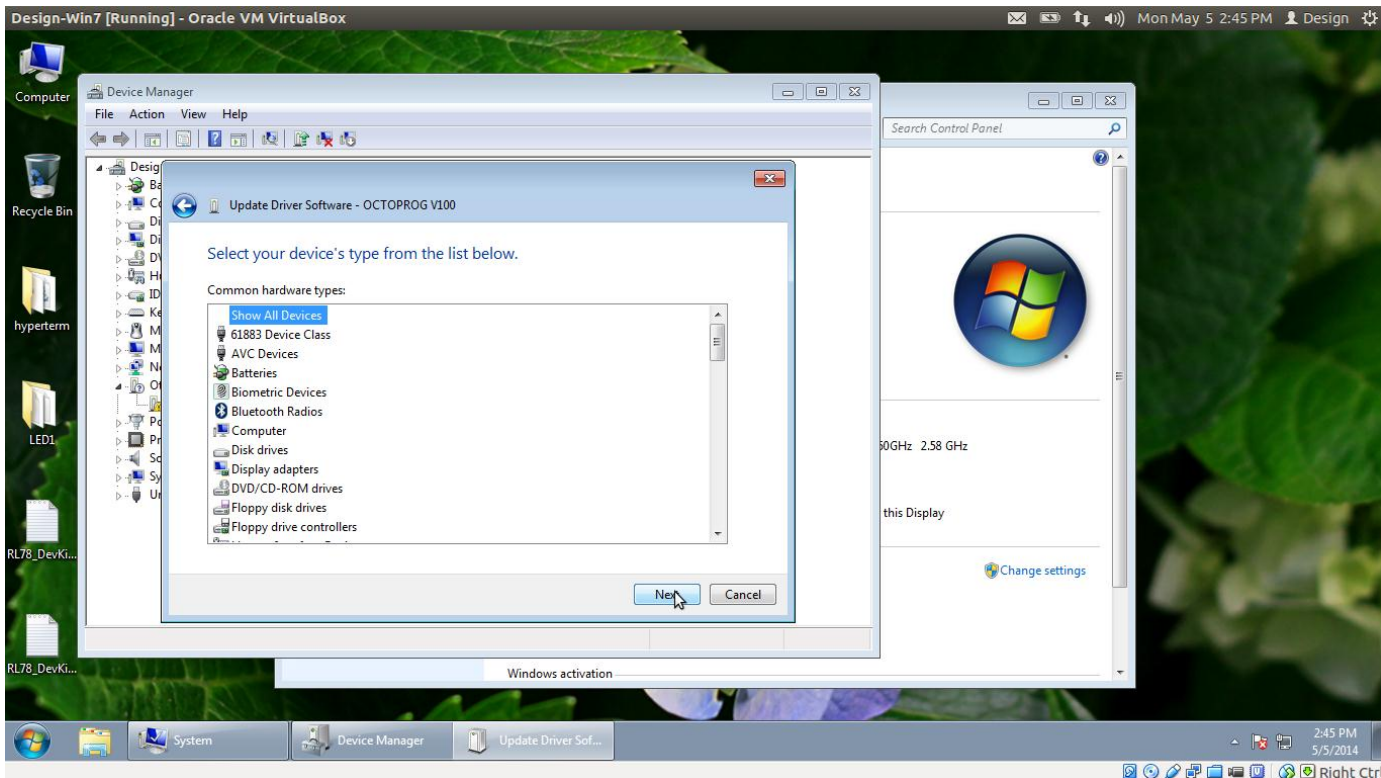

Figure 2.4

5. Select **Have disk**

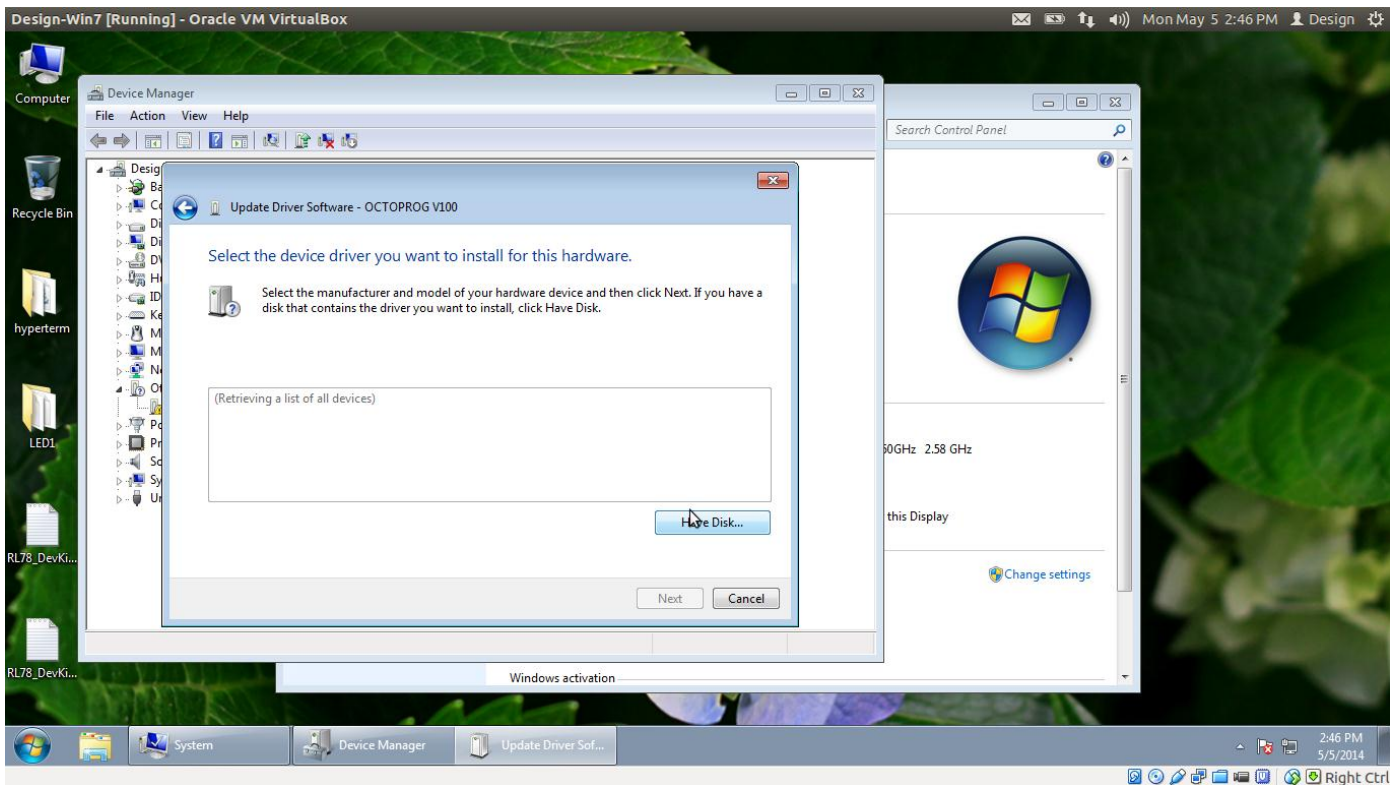

Figure 2.5

6. Select Browse

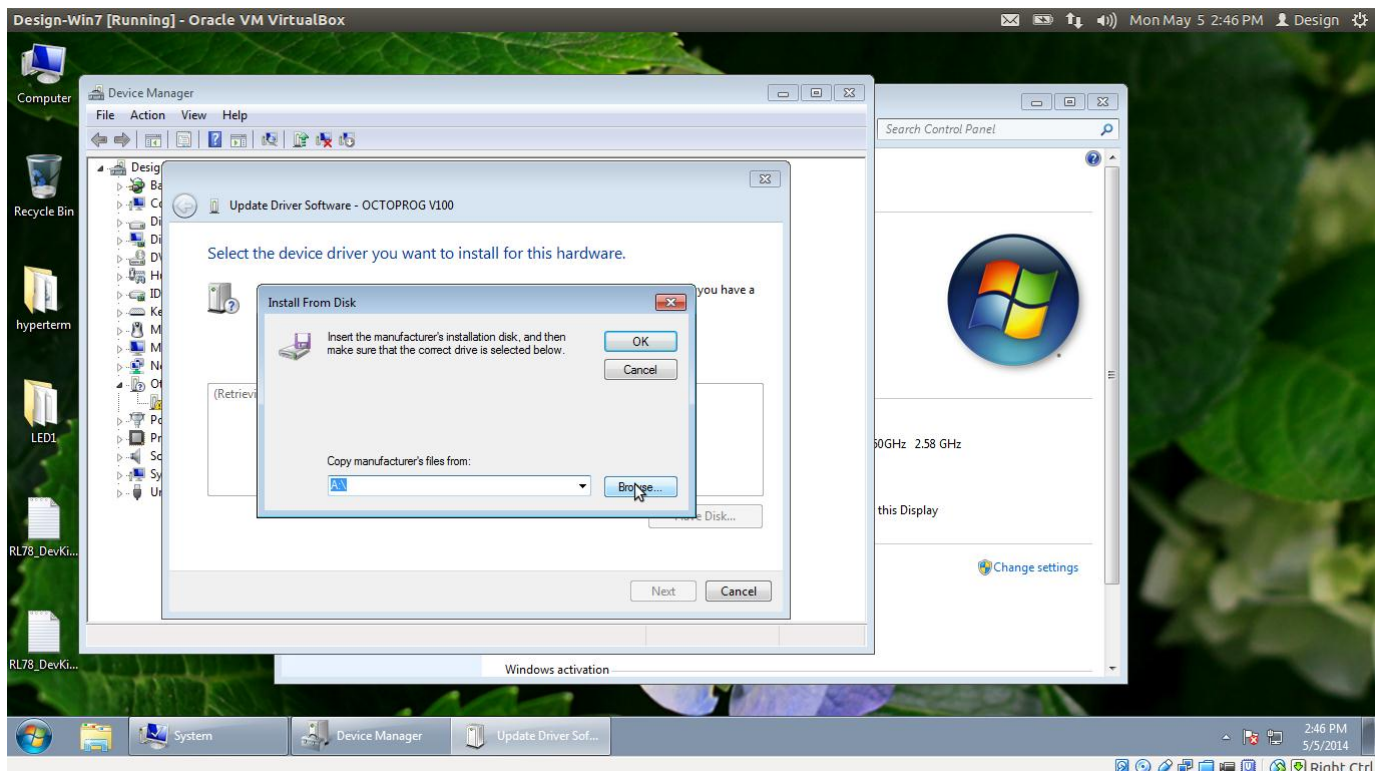

Figure 2.6

7. Select Octoprogram.inf file.

8. Select Yes

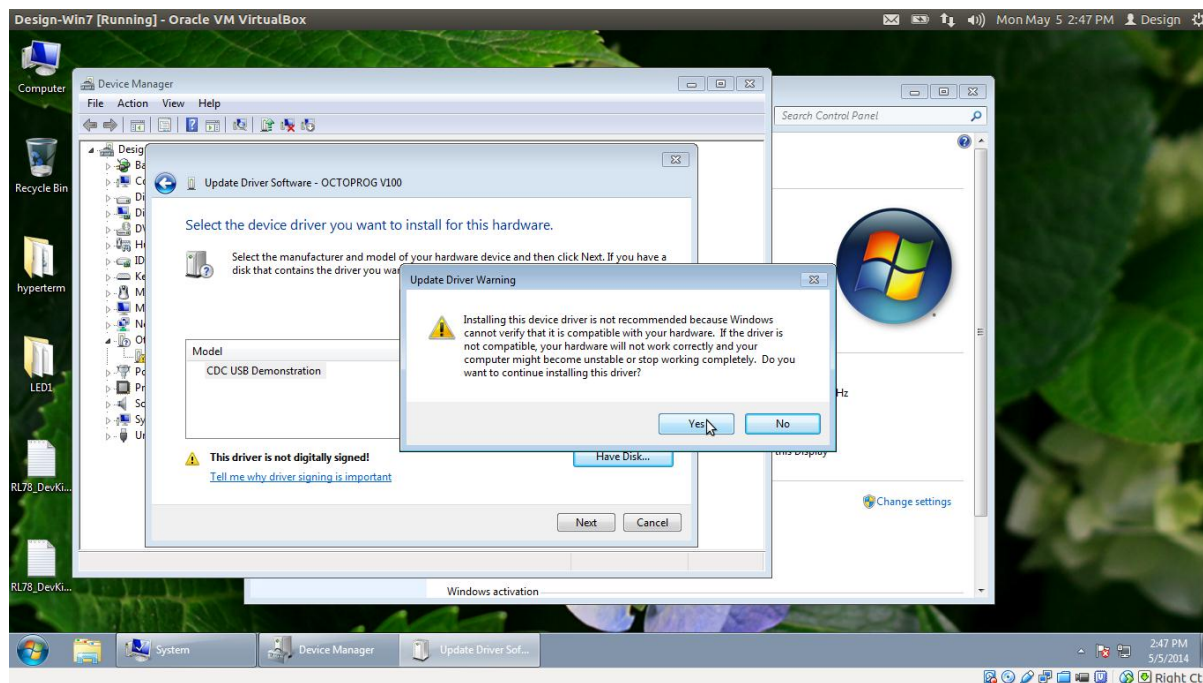

Figure 2.7

9. Select Install this driver software anyway

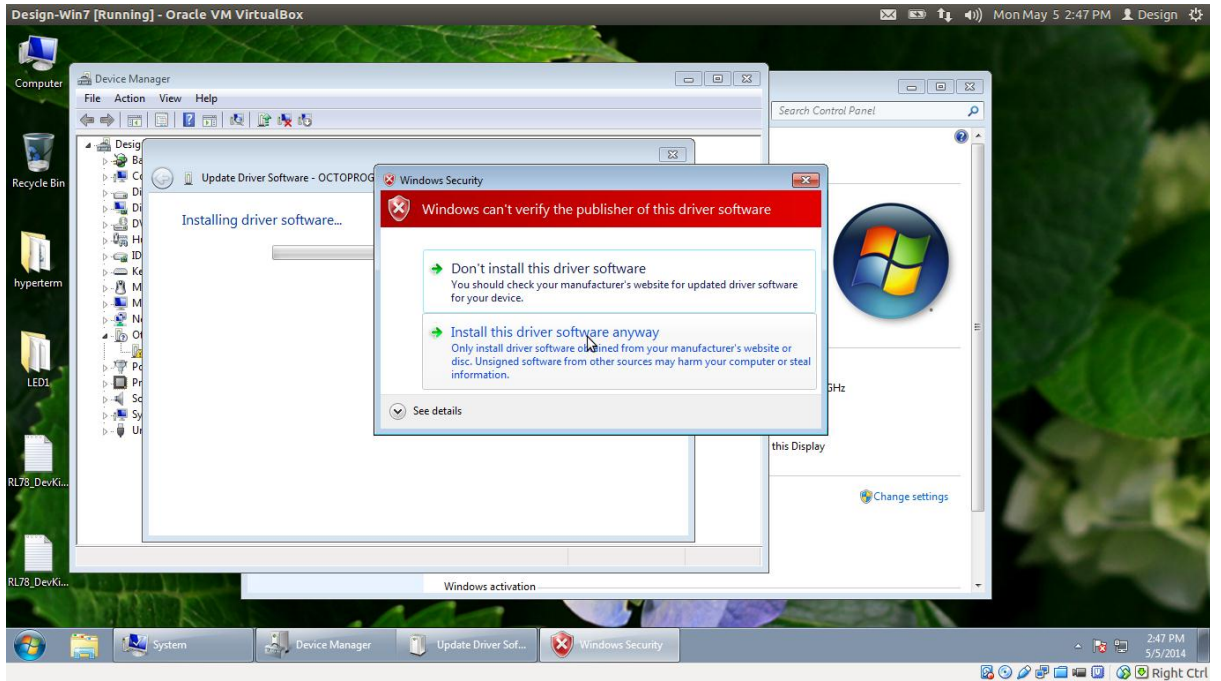

Figure 2.8

10. Driver successfully installed

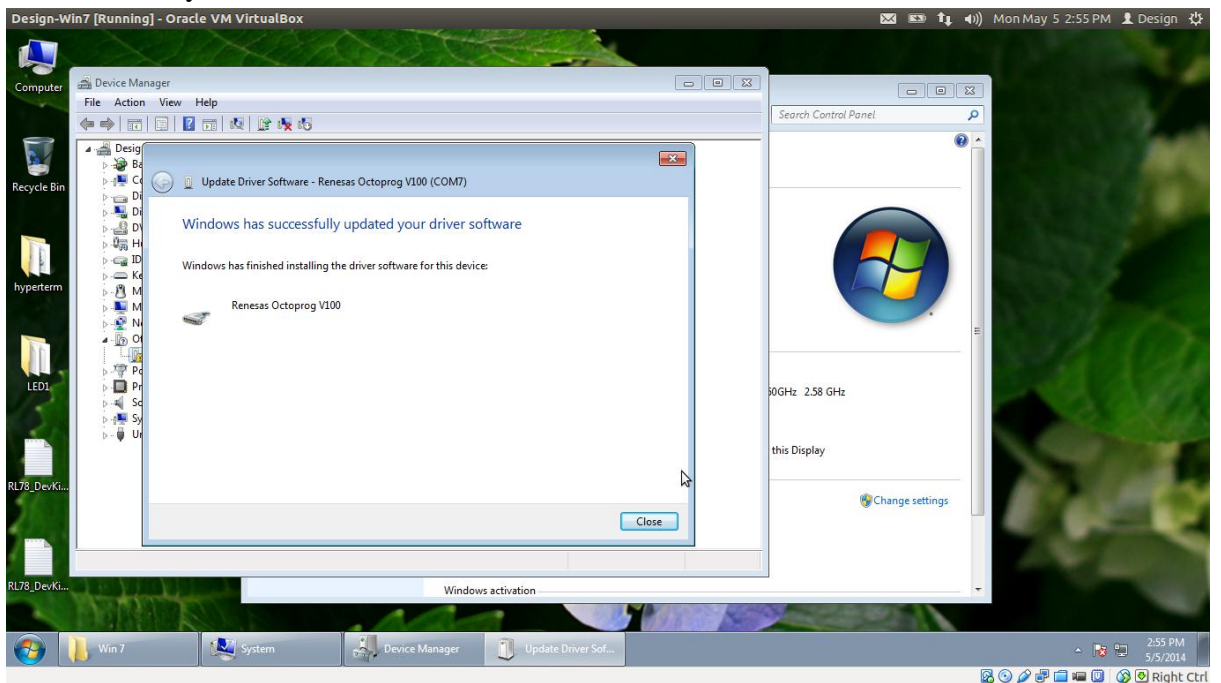

Figure 2.9

11. Driver is installed properly

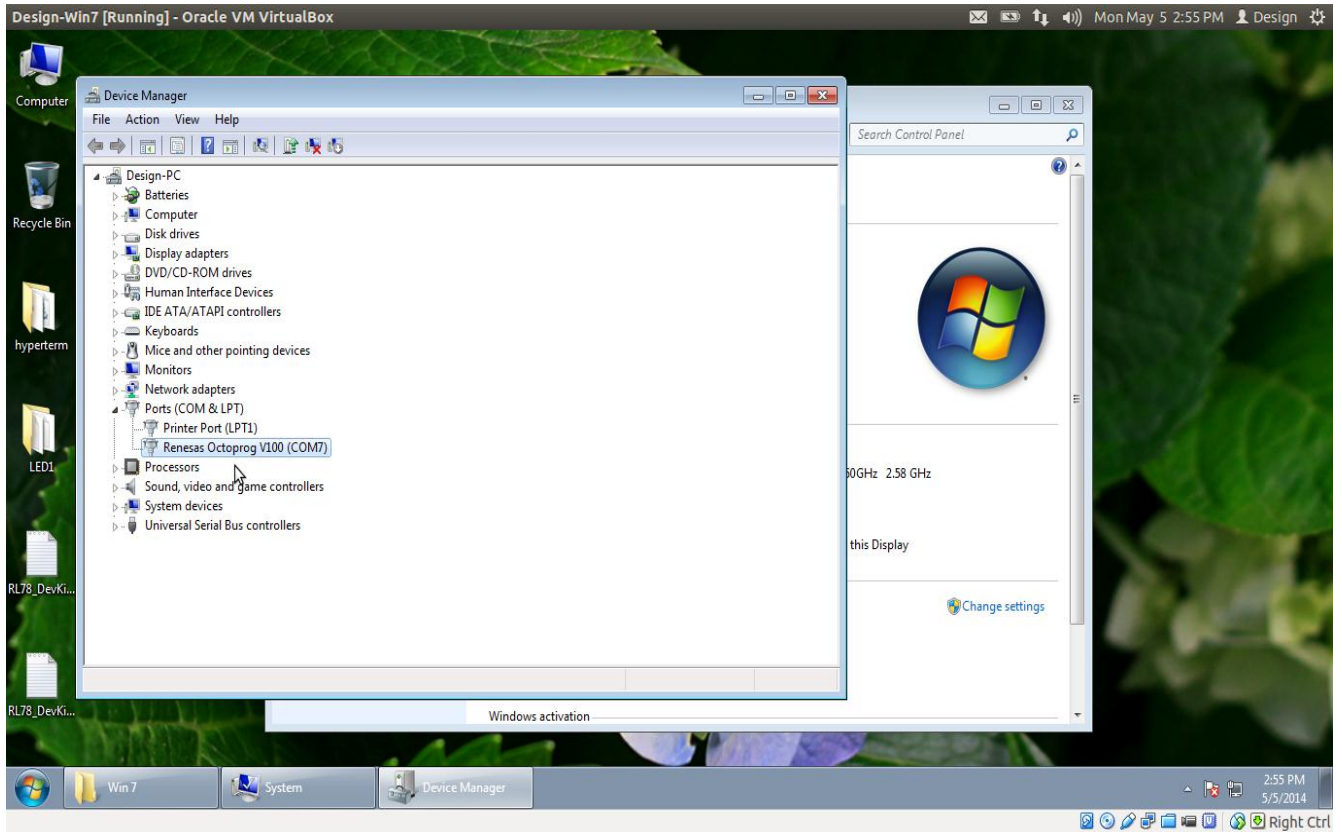

Figure 2.10

2.3 Running Crypto+ Application

Octoprog+ has two modes: USB_MODE & PROGRAM_MODE.

To get into USB_MODE, we have to power up the Octoprog+ pressing the **START** switch simultaneously. When you get into USB_MODE, all LEDs will blink once. When we just power up the device, it will get into PROGRAM_MODE& all LEDs turn red, blue, and green in order then turned off.

To download a program from the PC to the Octoprog+:

Power up the Octoprog+, pressing the **START** switch to get into the USB mode. USB cable should be connected to the PC.

2.3.1 Create a New Project

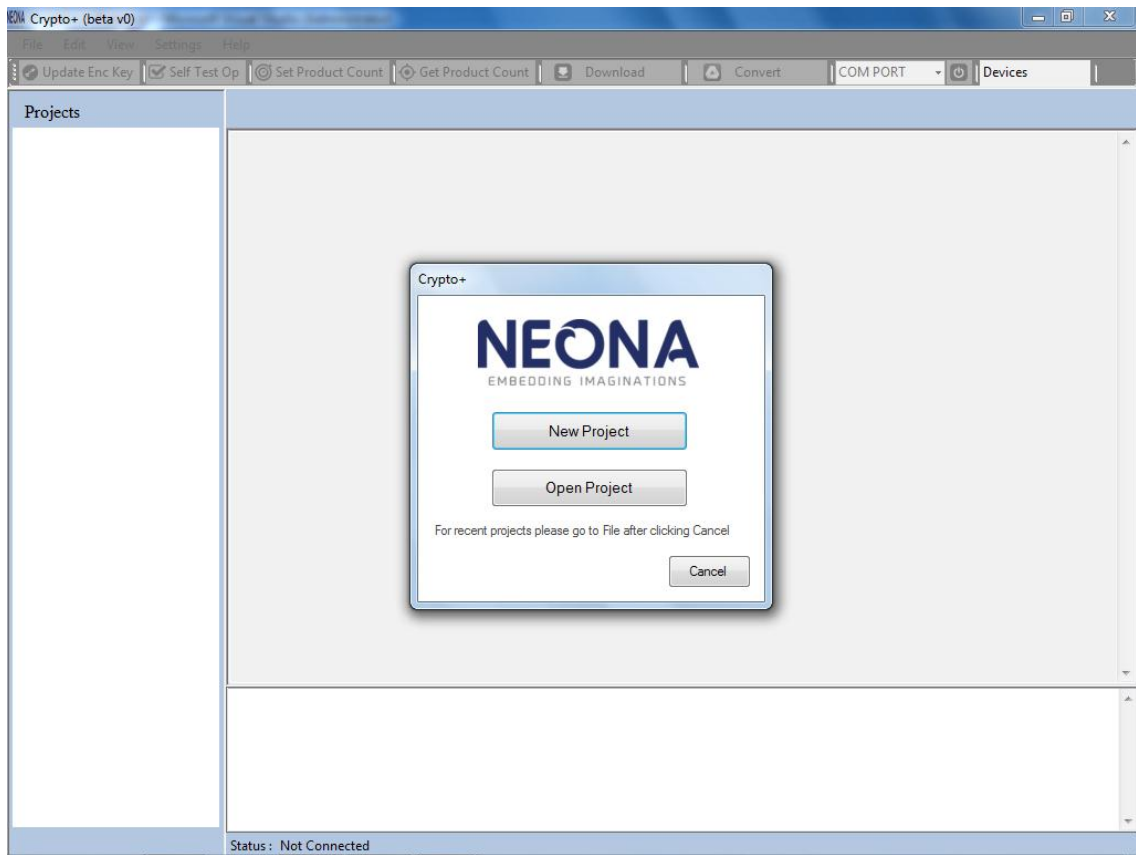

Figure2.11

STEP 1: To create a new project, start the application & click on **New Project** button as shown in figure 2.11 or if the application is already opened, then new project can be created from **File->New Project** as shown in figure 2.12.

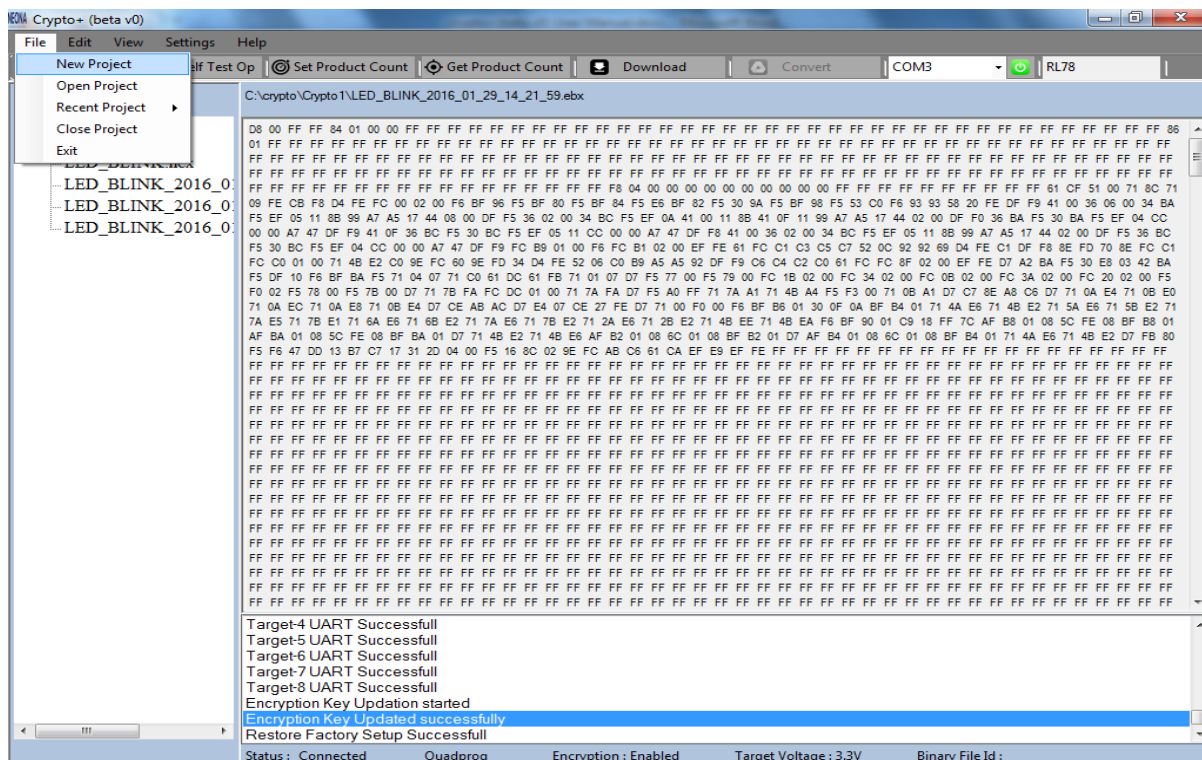

Figure 2.12

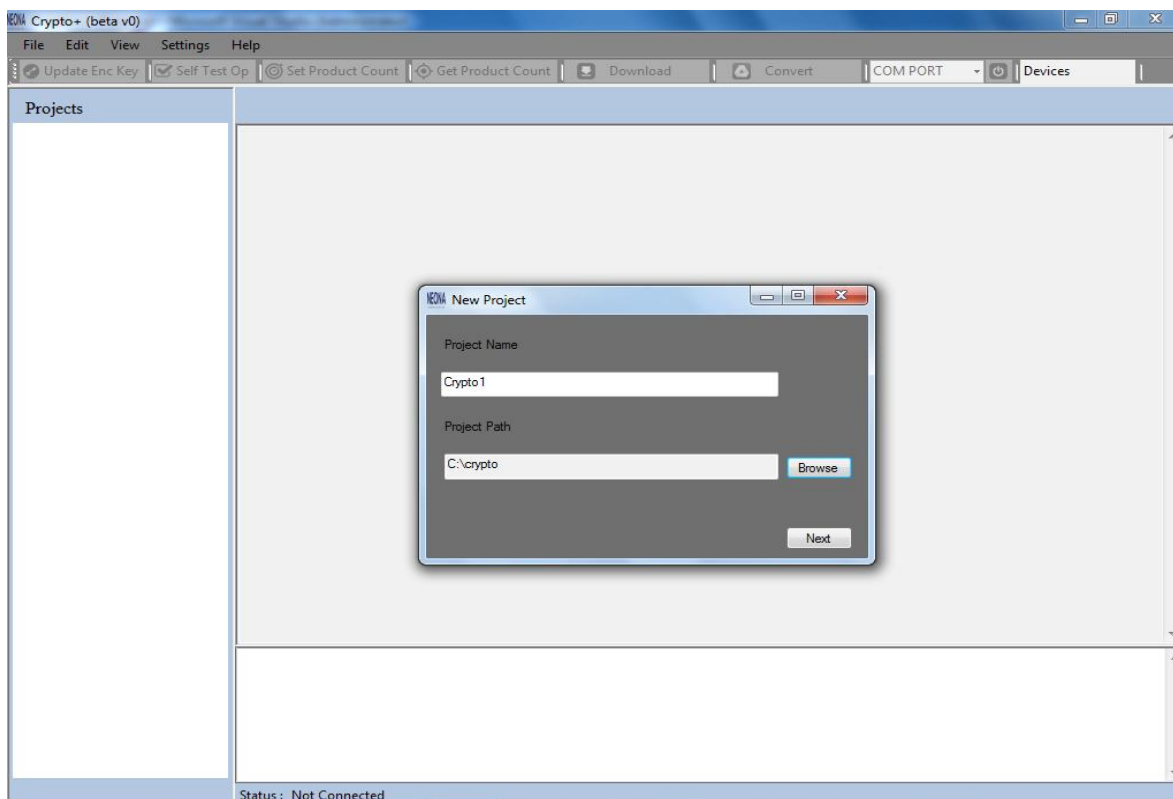

Figure 2.13

STEP 2: Enter your **project name** in the textbox.

STEP 3: Click **Browse** to select your project location.

STEP 4: Click **Next** as shown in figure 2.13.

STEP 5: Select Device- Choose the appropriate microcontroller from the list as shown in figure 2.14.

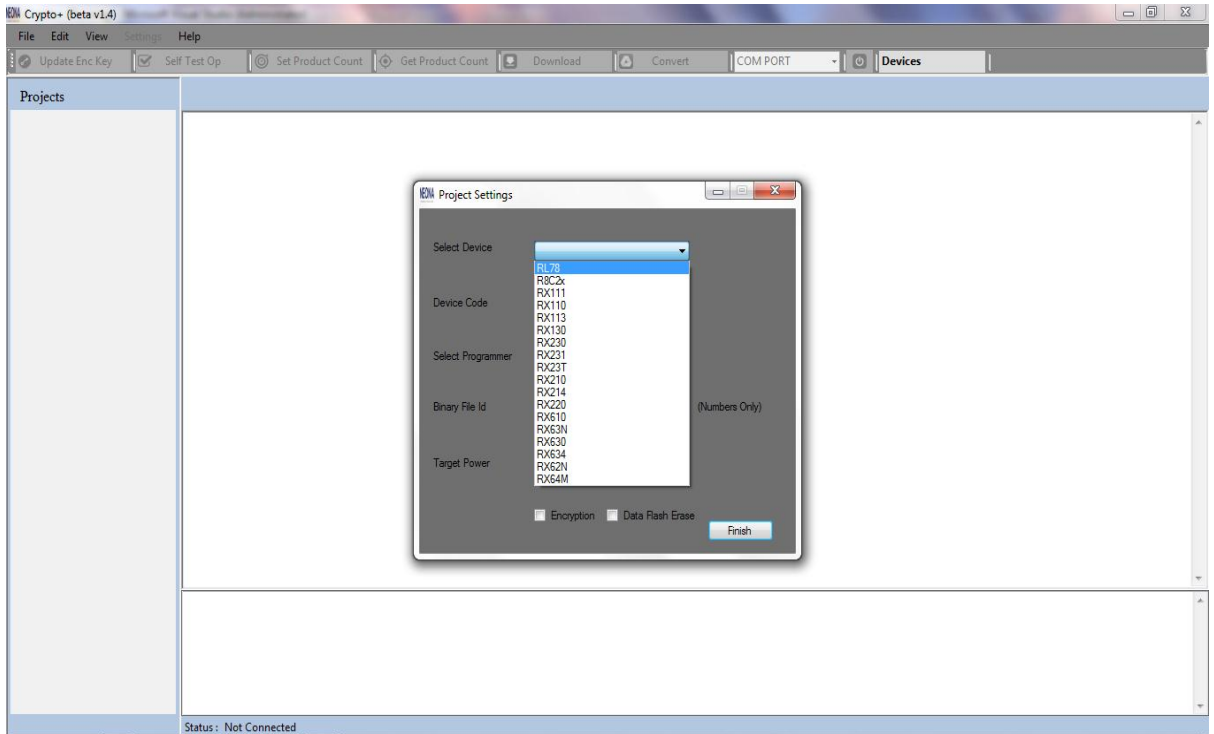

Figure2.14

STEP 6: Enter Device Code- Enter the part number of the microcontroller. This option is available only for RX/RL78.

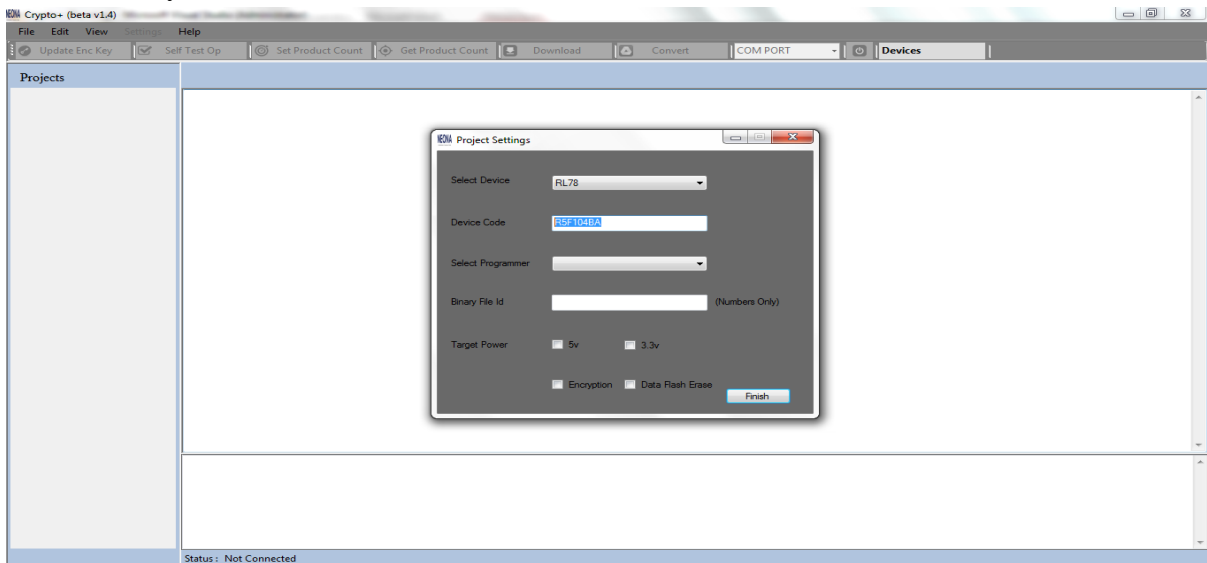

Figure 2.15

STEP 7: Select Programmer- A list of supported programmers will be shown in the Select Programmer field as shown in figure 2.16. Select the programmer that you want.

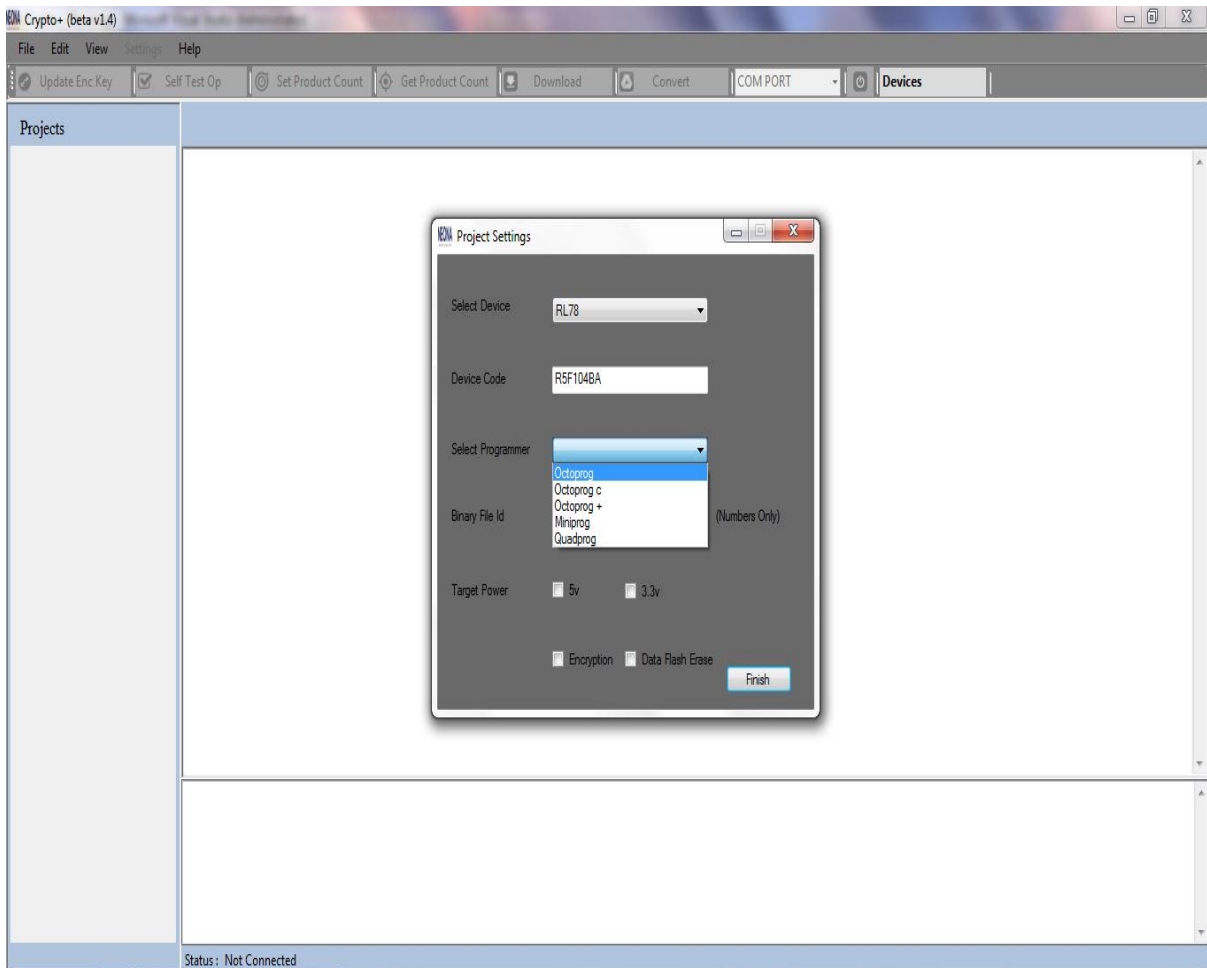

Figure 2.16

NOTE:

- RL78 is supported by all the programmers.
- R8C2x is not supported in quadprog
- RX will be supported only in quadprog

STEP 8: Enter Binary File Id- Enter your 8-digit BINARY FILE ID in the Binary File Id field. File ID consists of only numbers as shown in figure 2.17.

- If you select Octoprogram then Binary file id is not needed.

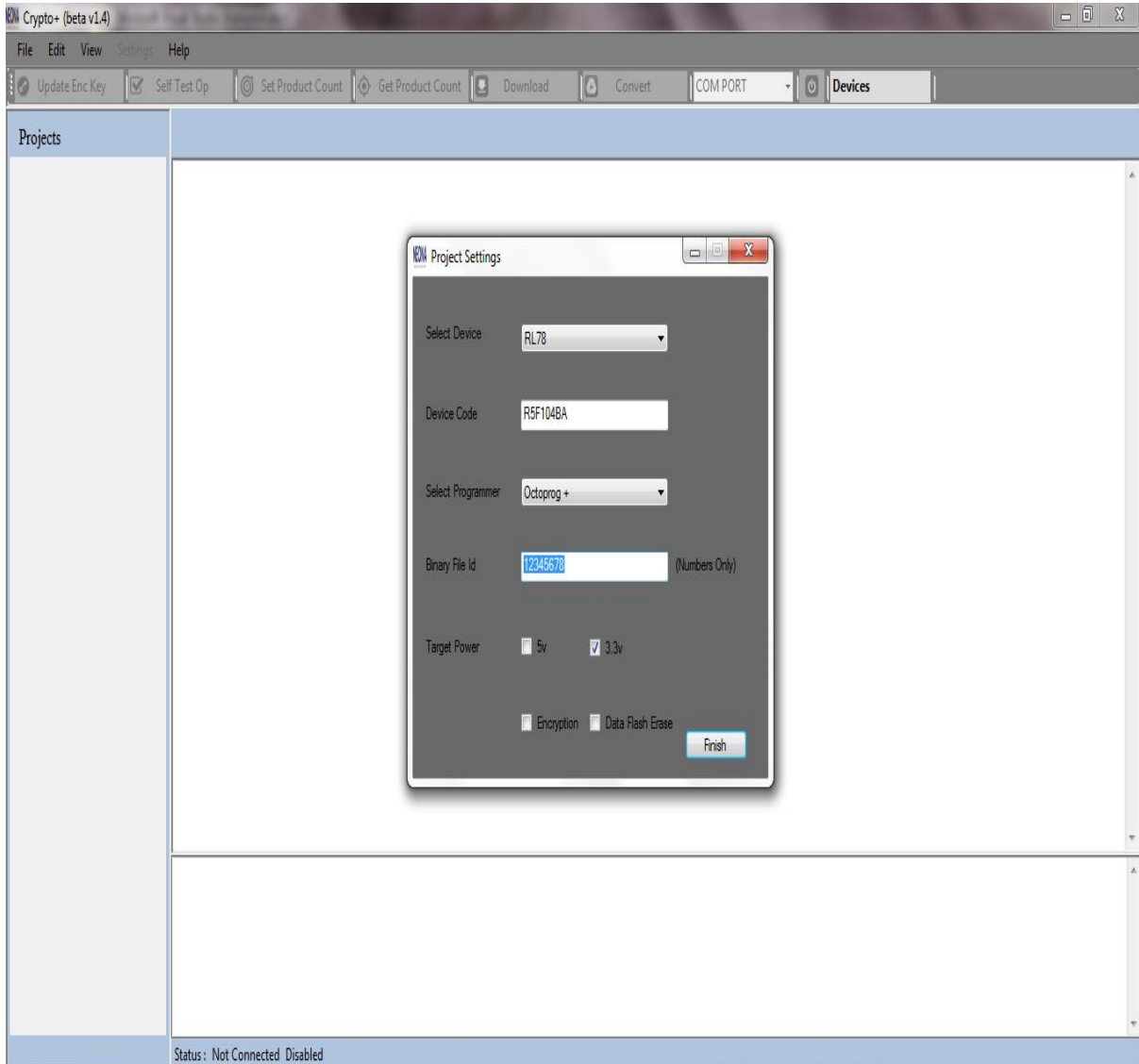

Figure 2.17

STEP 9: Select Target Power- Either you can select 5V or 3.3V. It depends on device and programmer that you have selected.

NOTE:

- 5V Enable option is available only for RL78/RX devices
- 5V Enable option is available only for quadprog & miniprogram

STEP 10: Select Encryption status-encryption can be enabled or disabled. It depends on device and programmer that you have selected.

- Encryption is always enabled for an R8C2x device.
- If the selected programmer is Octoprog then Encryption is always enabled.

STEP 11: Select Data Flash Erase- Data Flash Erase can be enabled or disabled.

Note:

This option is not available in Octoprog & Octoprog C

STEP 12: New project Created- Click finish. Now the new project is created successfully. The project and the files can be seen in the tree-view and a message ‘New Project Created Successfully’ will be displayed in the text view as shown in figure 2.18.

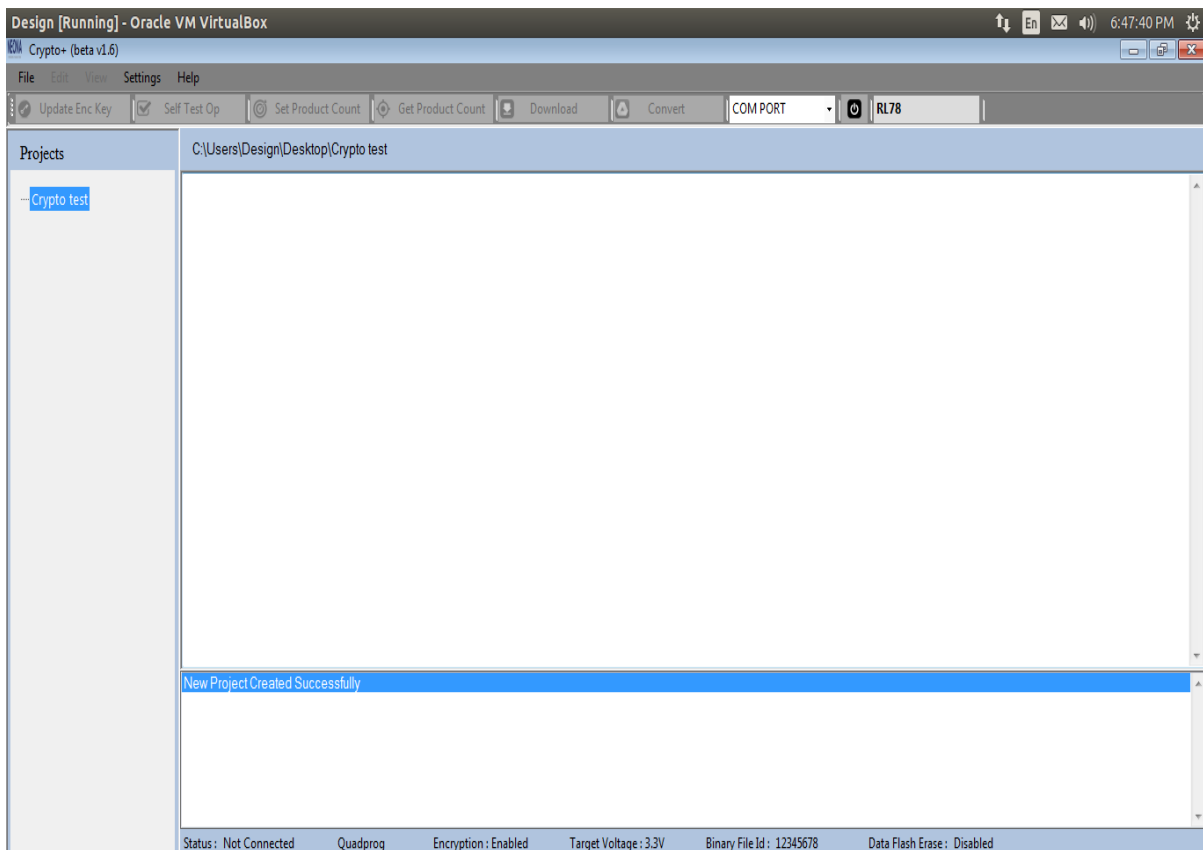

Figure 2.18

2.3.2 Open Project

STEP 1: Start the application and click the **Open Project** button as shown in figure 2.19. If the application is already opened, then a project can be opened using **File->Open** option.

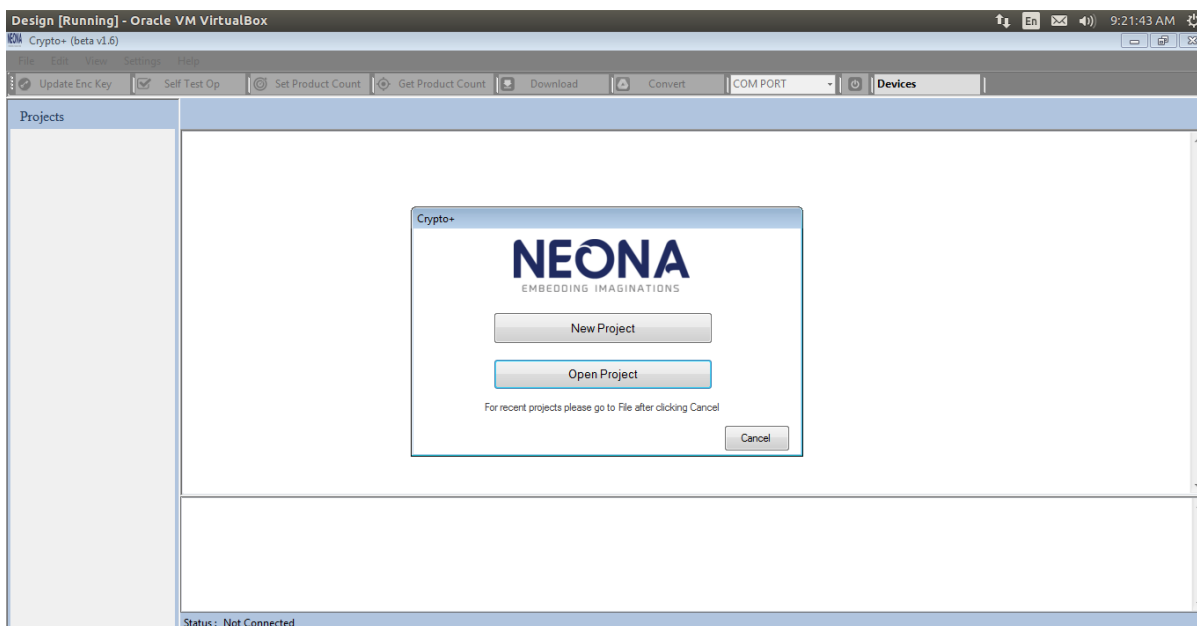

Figure 2.19

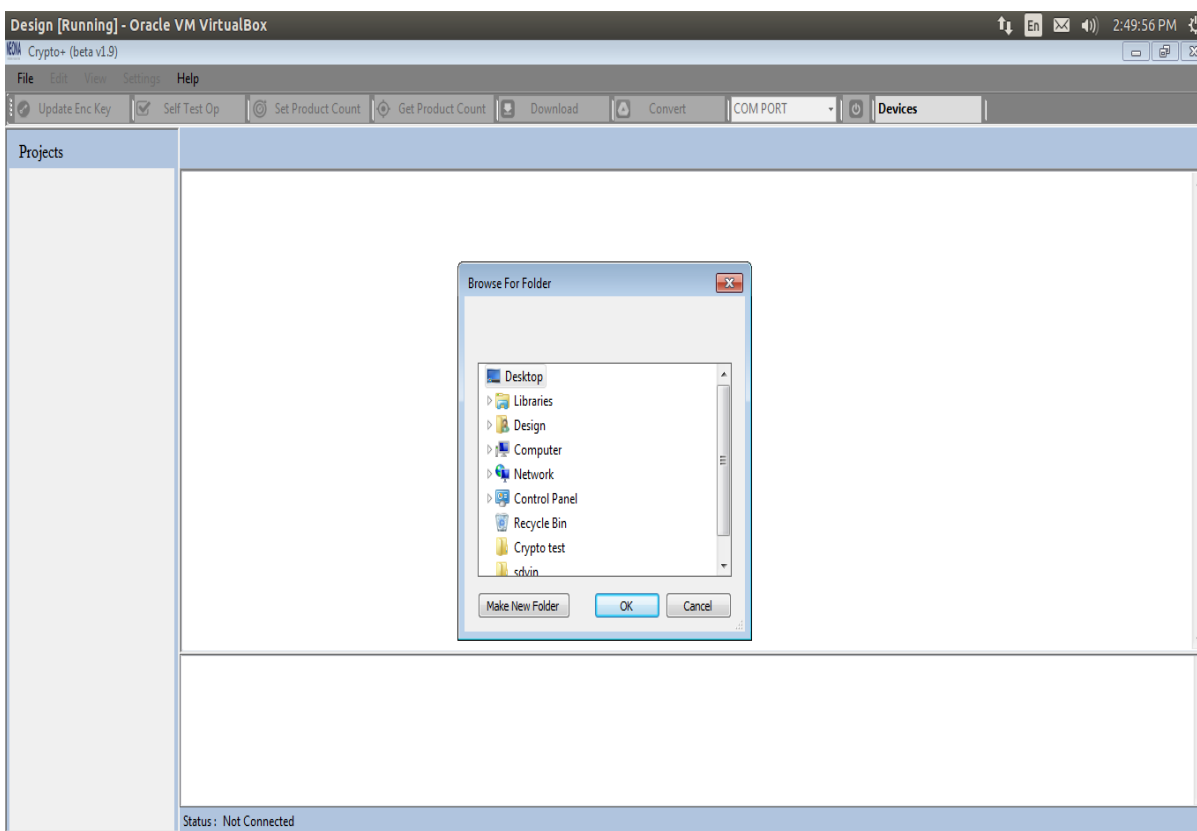

Figure 2.20

STEP 2: Browse for folder window appears as shown in figure 2.20.

STEP 3: Select the desired project.

STEP 4: Click OK.

2.3.3 Add Files to Project

We can add files (Hex, mot, bin, bx, ebx) to the created project.

STEP 1: Right click on the project name displayed in the tree-view as shown in figure 2.21.

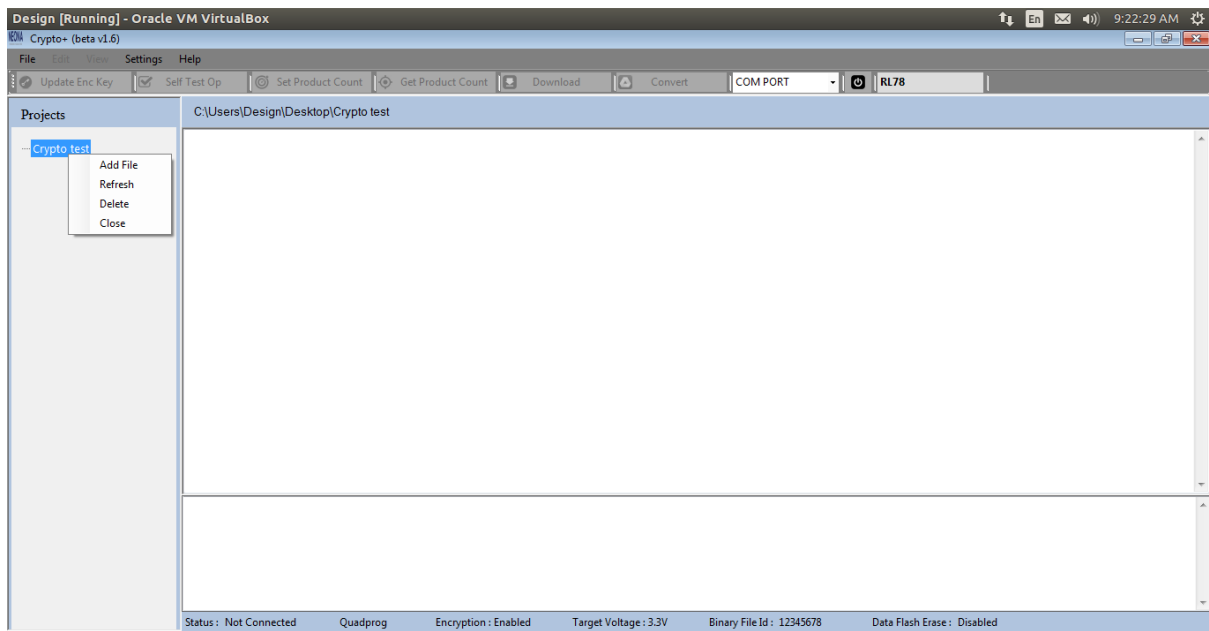

Figure 2.21

STEP 2: Click on **Add File** option in the context menu-strip.

STEP 3: Select the required file and click **Open** button in the Open Dialog-box as shown in figure 2.22.

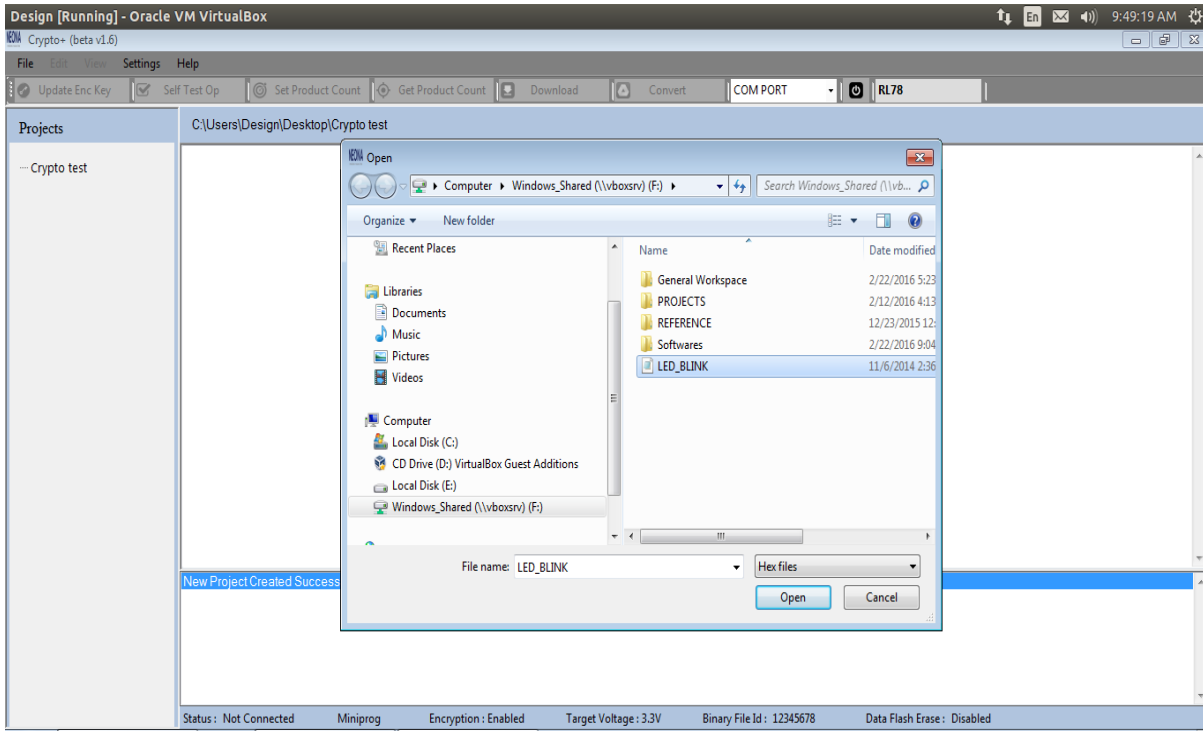

Figure 2.22

STEP 4: The added files will be listed in the tree-view and a message ‘**File Added Successfully**’ is displayed in the text view as shown in figure 2.23.

STEP 5: To view file content in the text box by double click on the file name in the Tree-view.

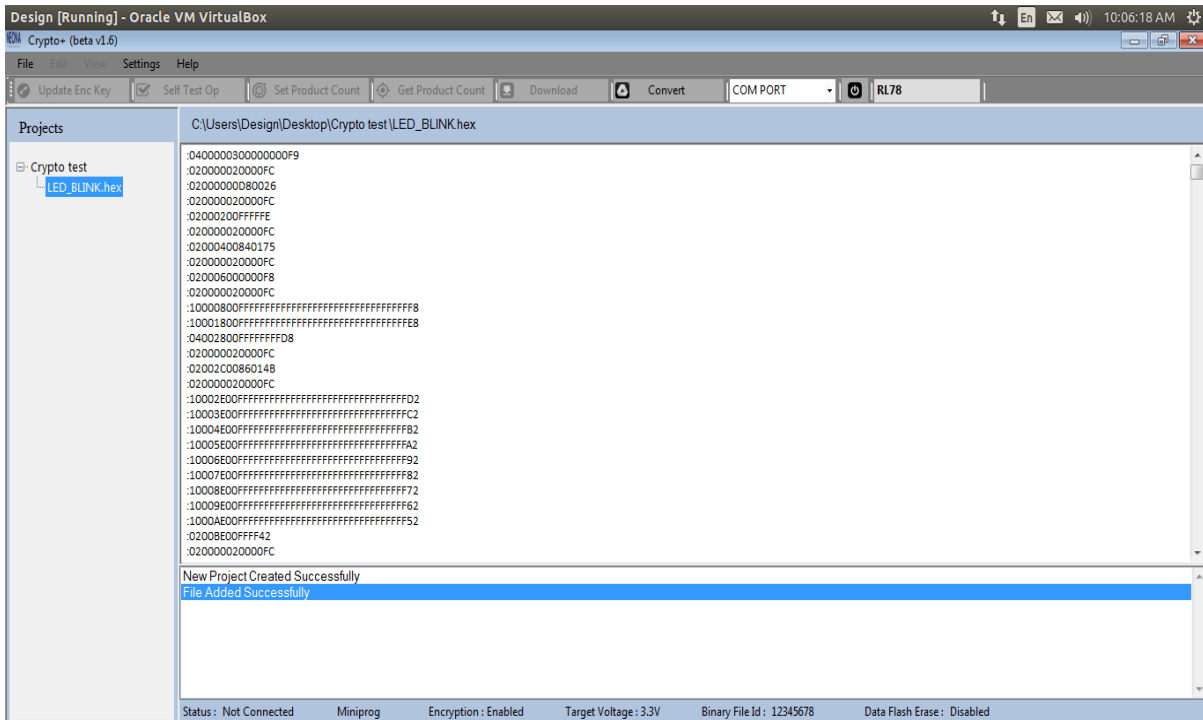

Figure 2.23

2.3.4 Convert files

The hex, bin or mot files can be converted to .bx file and the encrypt it to create an .ebx files.

- **To convert to .bx file:**

STEP 1: Disable the encryption. Click on the required hex or mot file in the tree-view & Click **convert** button displayed in the toolbar as shown in figure 2.24.

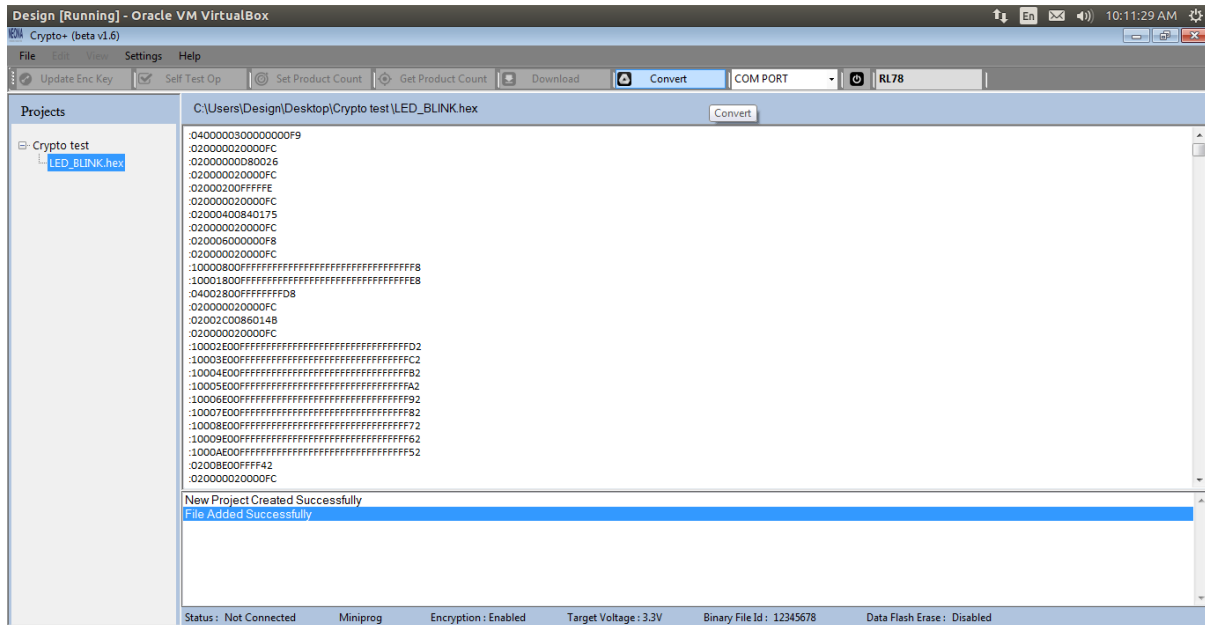

Figure 2.24

STEP 2: Converted .bx file will appear in the tree-view and if the conversion was successful a message 'Binary file creation finished' is displayed in the text view as shown in figure 2.25.

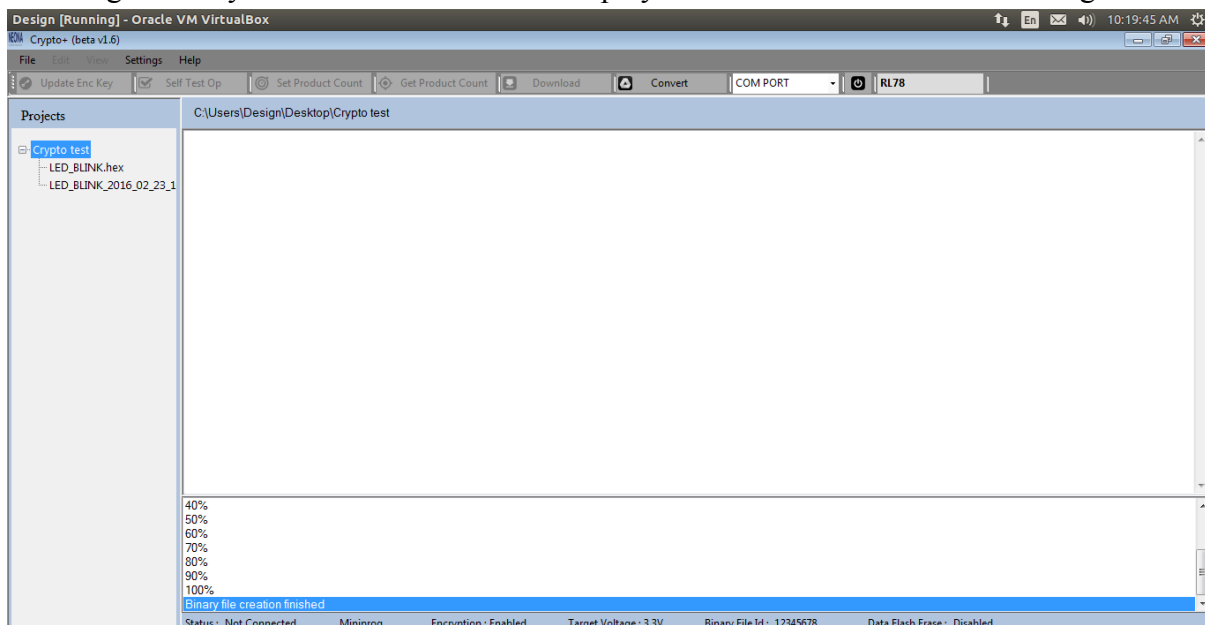

Figure 2.25

- **To covert to .ebx file**

STEP 1: Enable the encryption. Click on the required hex or mot file in the tree-view.

STEP 2: Click **Convert** button in the tool strip.

STEP 3: Converted .bx file will appear in the tree-view and if the conversion was successful a message ‘Binary file creation finished’ is displayed in the text view as shown in figure 2.25 & it will prompt for the encryption key.

STEP 4: Enter the 16 digit encryption key& click **OK**.

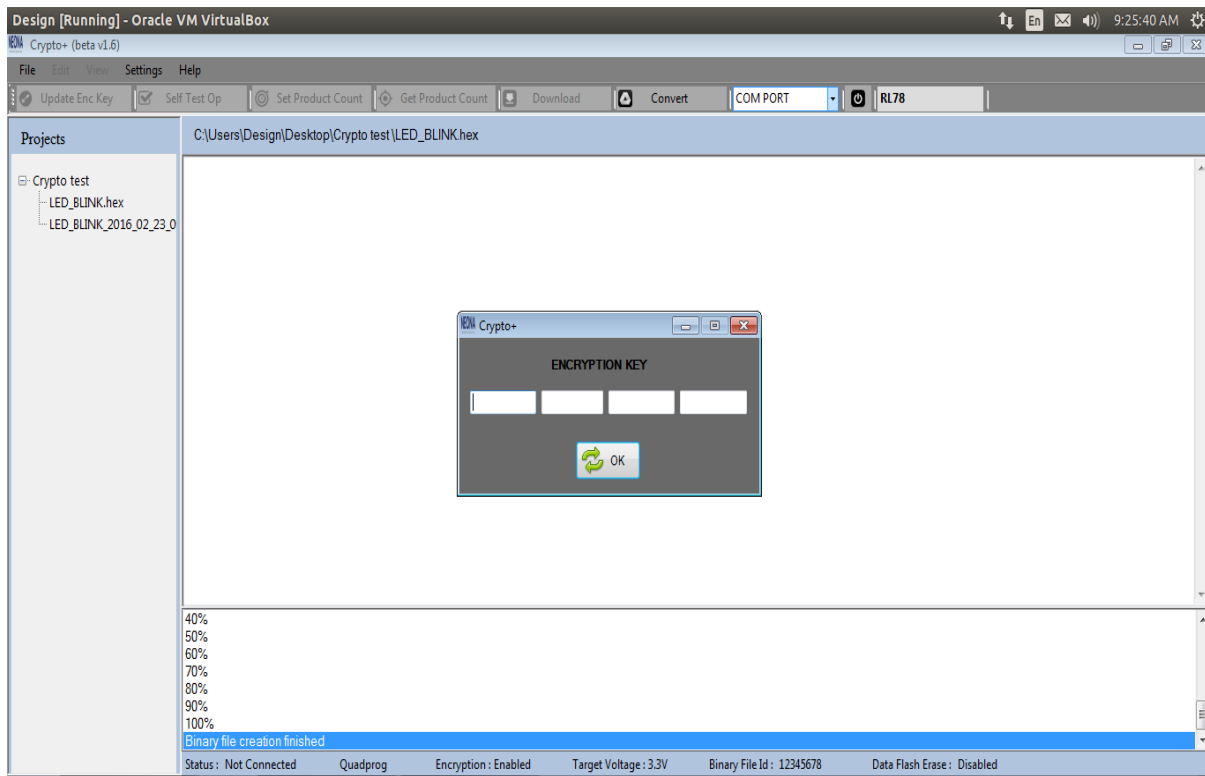

Figure 2.26

STEP 5: After the successful creation of the .ebx file a message ‘new output ebx file created’ is displayed in the text view and the .ebx file will be added in the tree-view as shown in figure 2.27.

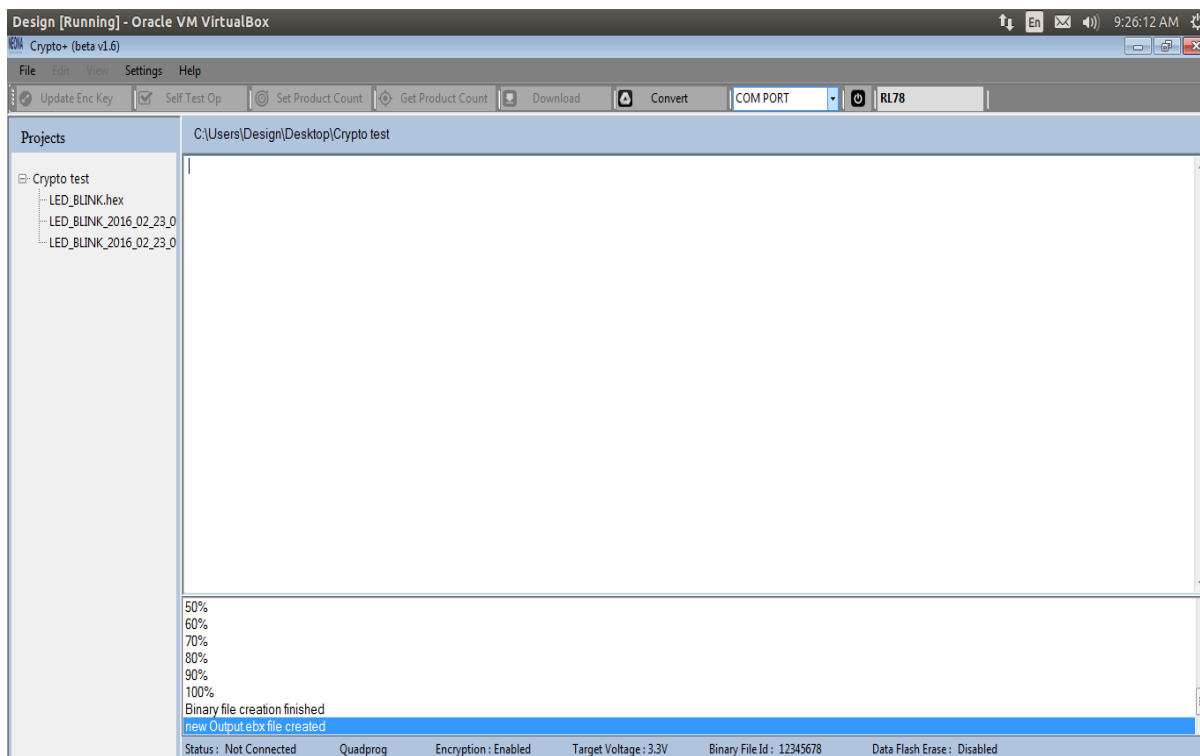

Figure 2.27

- **To convert a .bin file**

STEP 1: Click on the required binary .bin file from the tree-view. Click **Convert** button in the tool strip.

STEP 2: Prompt for entering start will be displayed as shown in figure 2.28. Enter the 8 digit start address & click on **OK**.

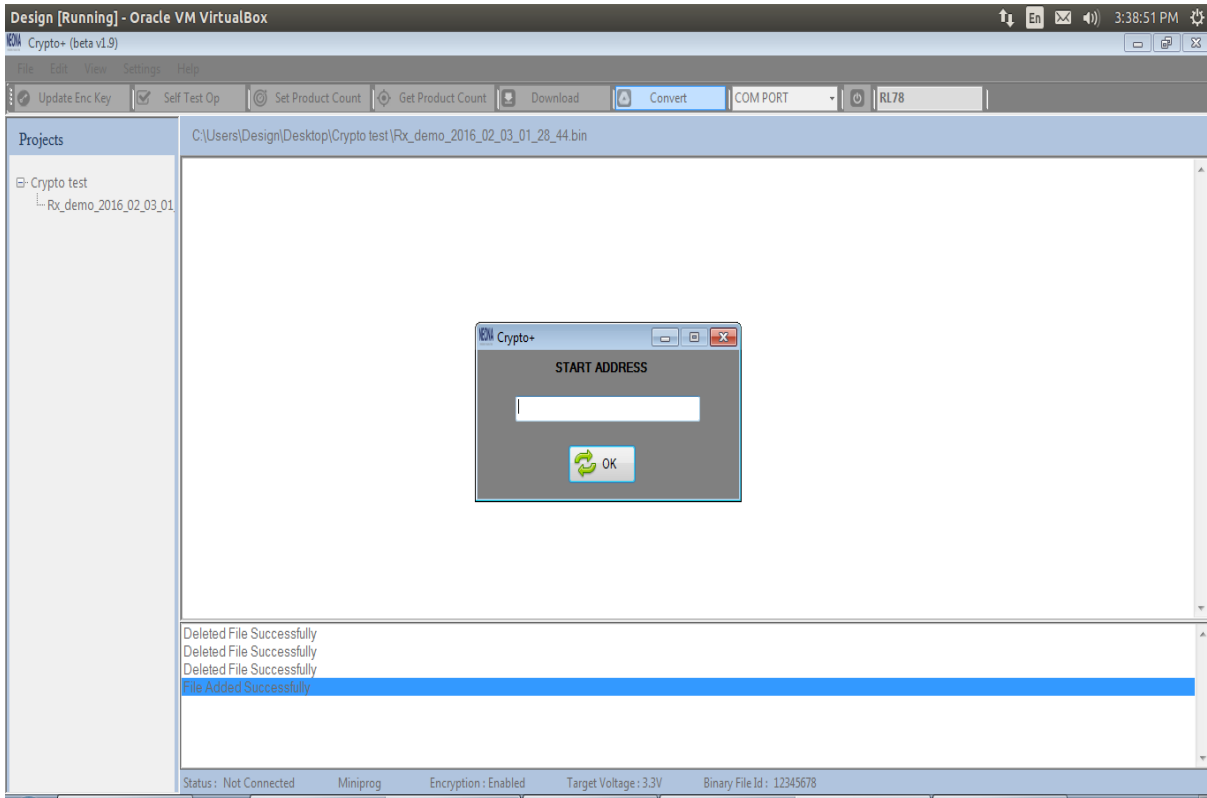

Figure 2.28

STEP 3: After the successful creation of the .bx file it will appear in the tree-view and a message ‘Binary file creation finished’ is displayed in the text view.

STEP 4: If encryption is enabled then after the .bx file creation, encryption key is asked as shown in figure 2.26. Enter the 16 digit encryption key and click OK button.

STEP 5: After the successful creation of the .ebx file a message ‘**new output ebx file created**’ is displayed in the text view and the ebx file will be added in the tree-view as shown in figure 2.29.

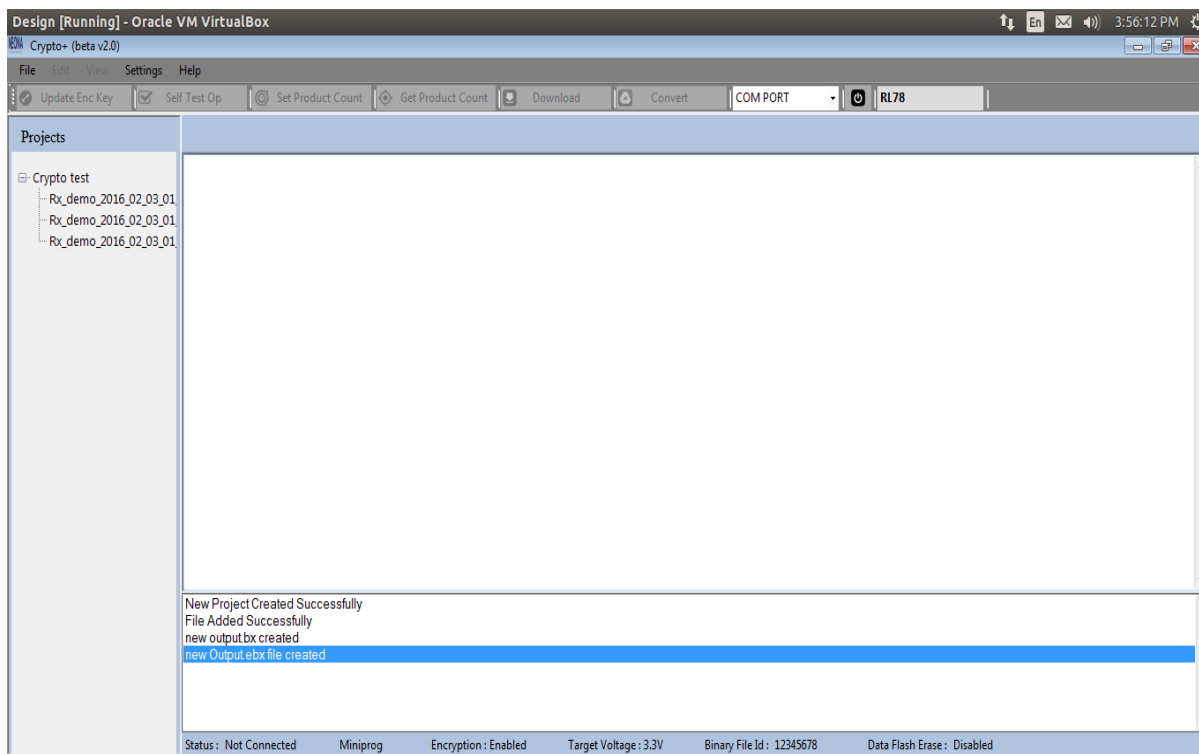

Figure 2.29

2.3.5 Connect to programmer

STEP 1: Select Com port to which the programmer is connected.

STEP 2: Click on Connect  button as shown in figure 2.30.

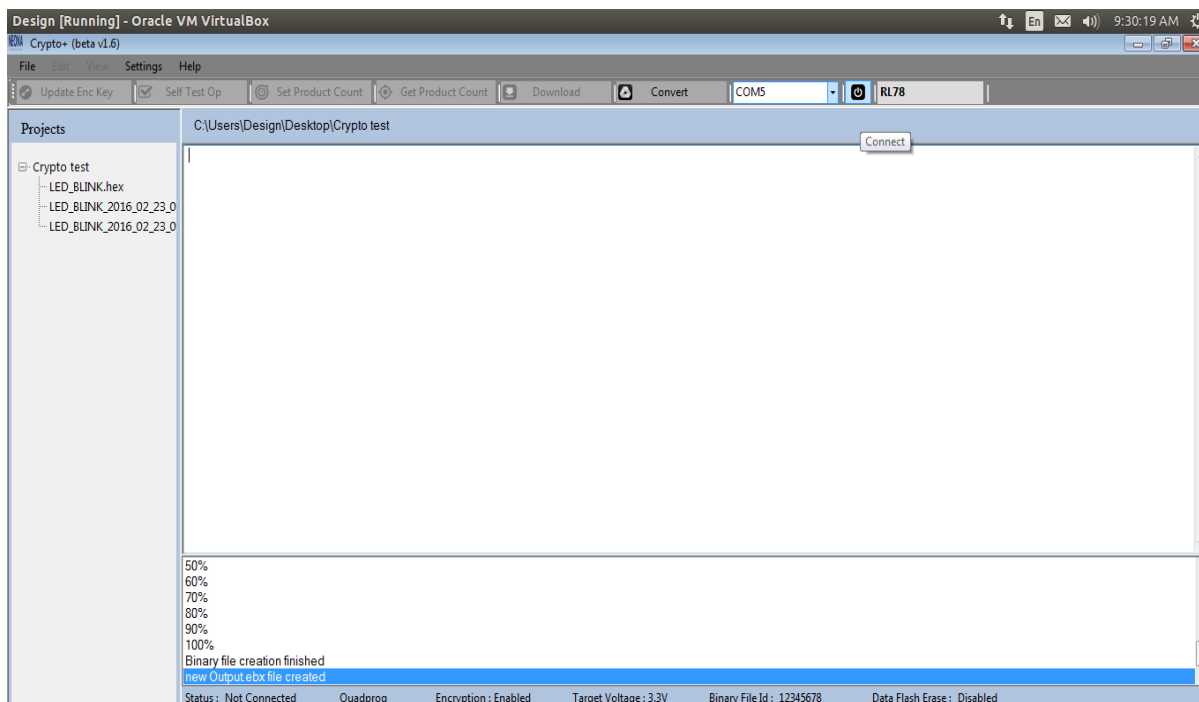

Figure 2.30

STEP 3: A window showing the firmware version & serial number will appear as shown in figure 2.31. Click **OK**.

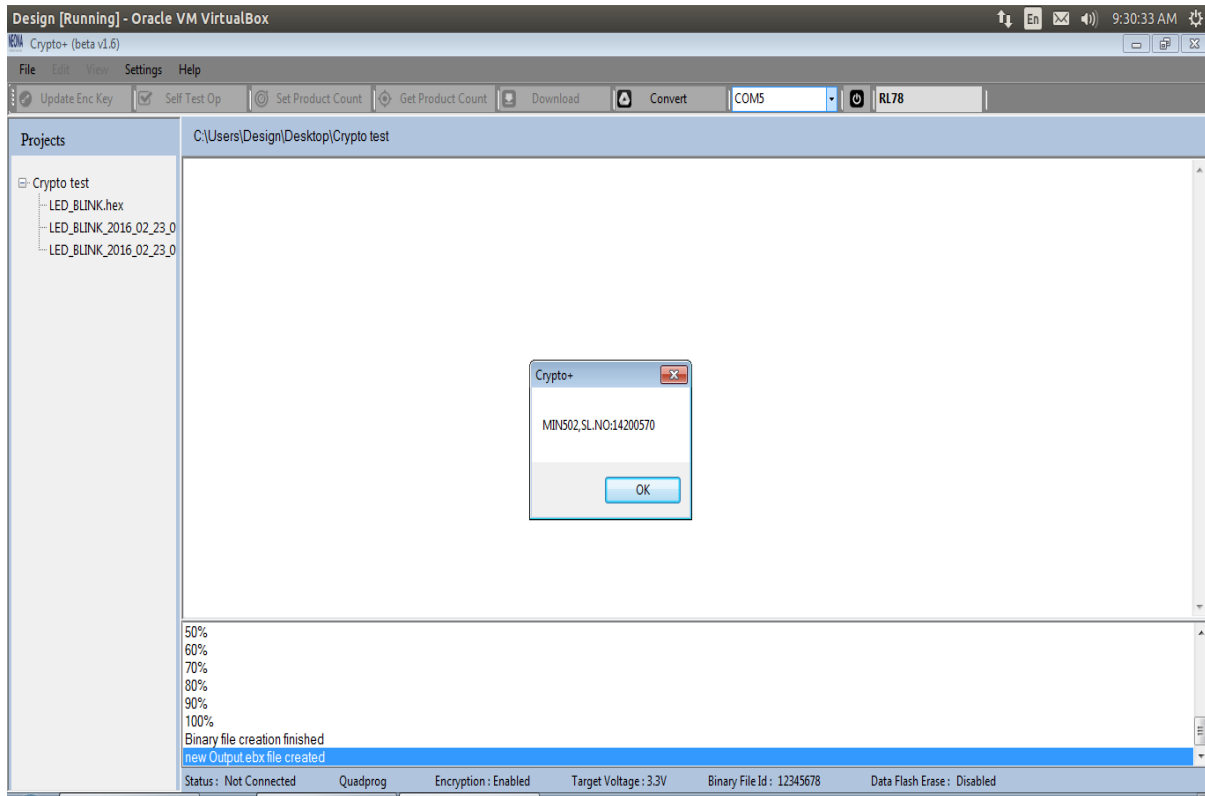

Figure 2.31

STEP 4: If connection is established, the connect button in the application will turn green and all programmer details will appear in the text view as shown in the figure 2.32.

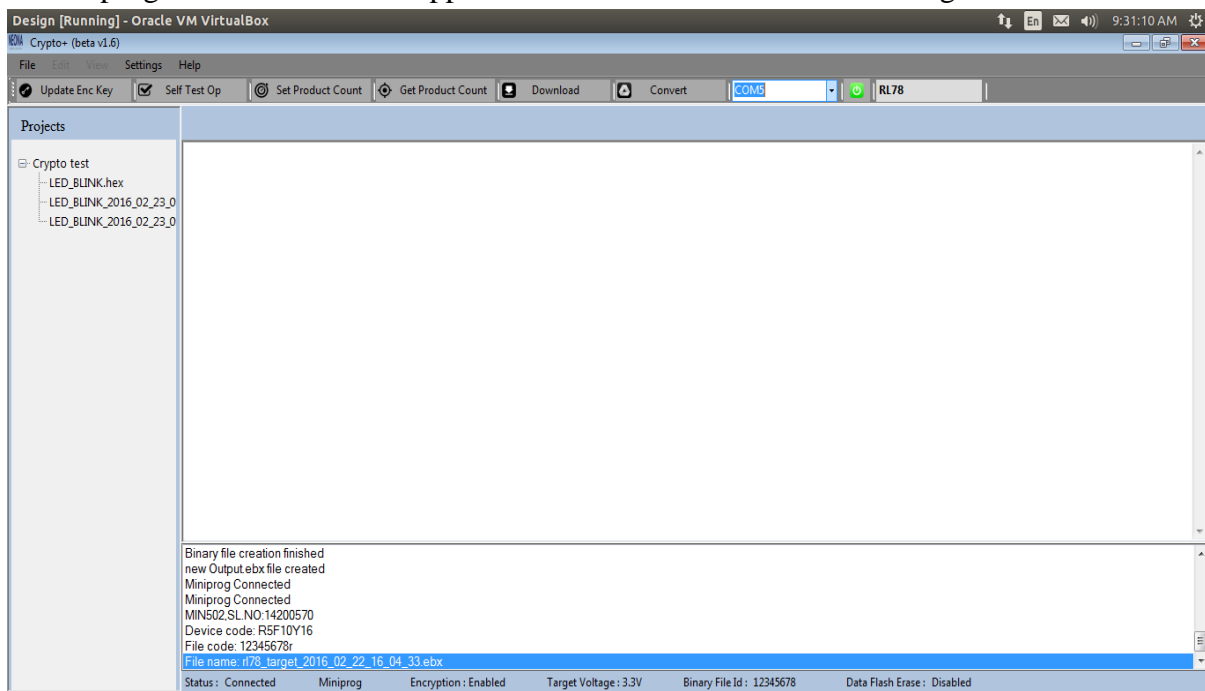

Figure 2.32

2.3.6 Download program to the programmer

STEP 1: If encryption is enabled in the settings and then select the encrypted file else select a .bx file from the tree-view. Click **Download** button.

STEP 2: Enter the device part number as shown in figure 2.33 & Click **OK**. A message ‘**File download finished**’ will appear in the text view and a window to set the product count will appear as shown in figure 2.34.

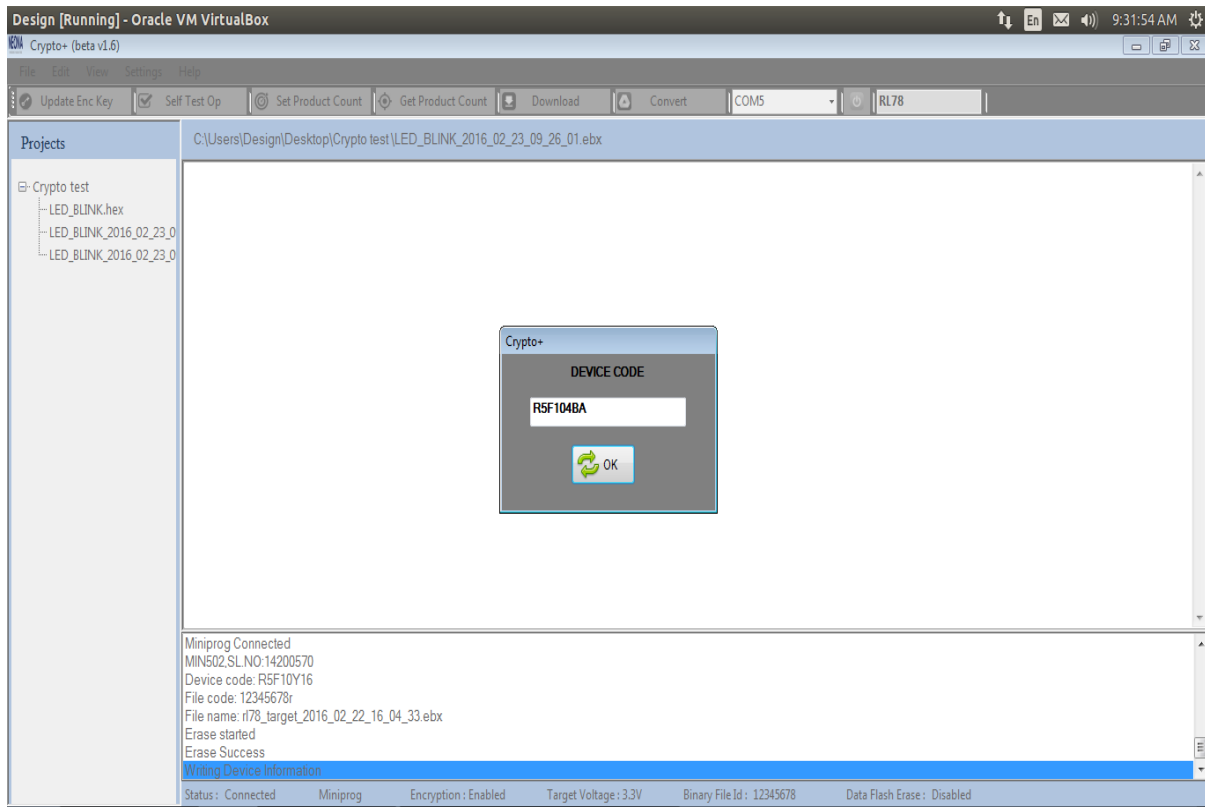

Figure 2.33

STEP 3: Set Product count-Provide the encryption key and the required product count & Click OK.

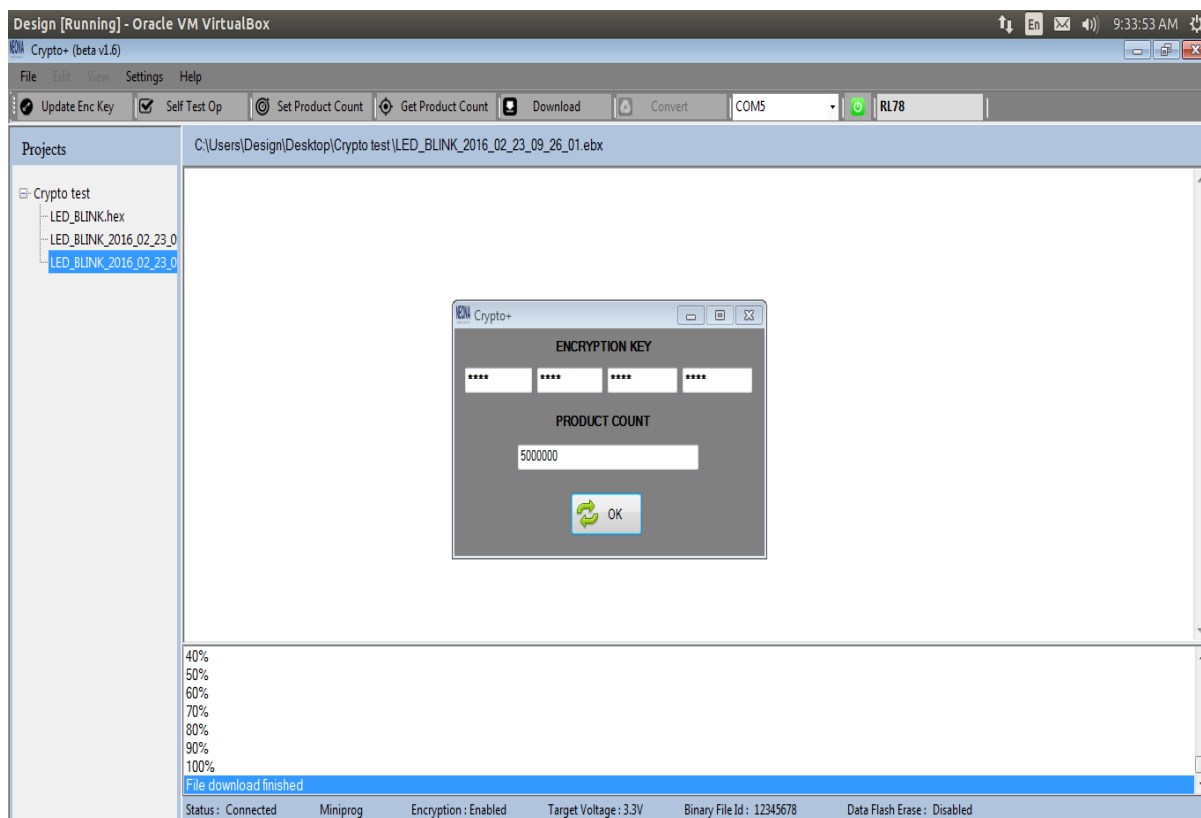

Figure 2.34

STEP 4: A message ‘Set Product count success’ will appear in the text view.

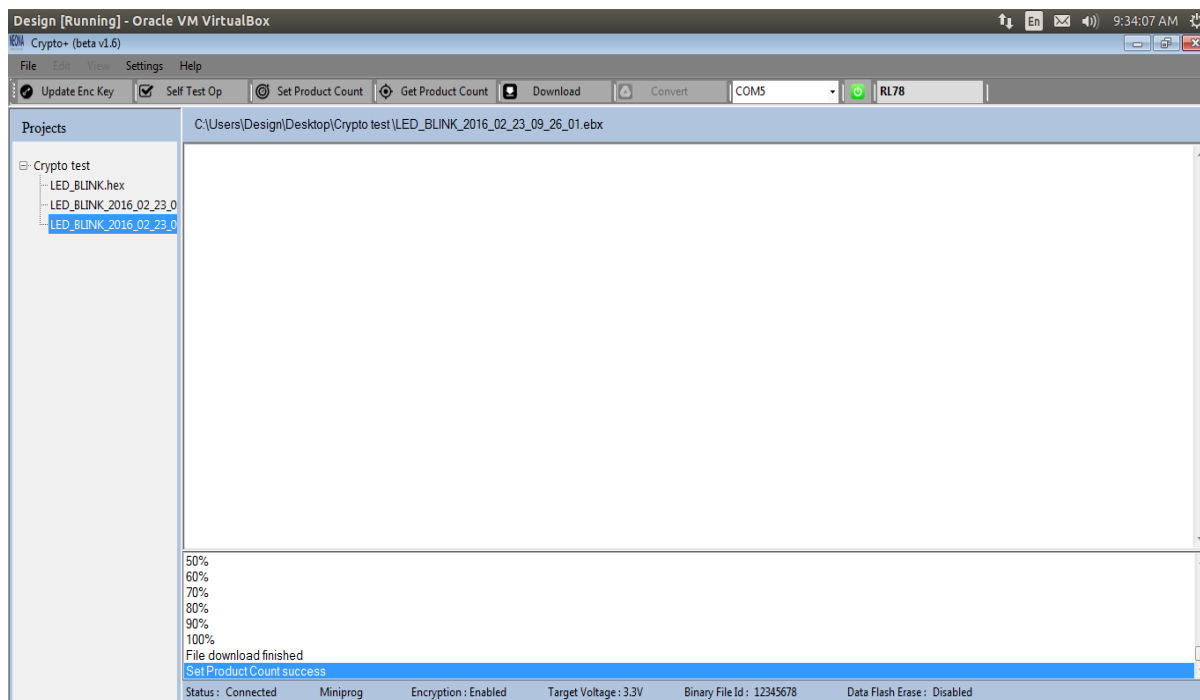

Figure 2.35

NOTE: For downloading the .bx file to the programmer disable the Enable encryption option in the Settings and then select the .bx file and click download button. In the case of R8C, .bx file cannot be downloaded to the programmer.

2.3.7 Set Product Count

Downloading a new program will erase the target count in the programmer. Therefore after downloading an encrypted/binary file, it is mandatory to set the target count in programmer.

STEP 1: Click **Set Product Count**. A window asking the encryption key and product count will appear as shown in figure 2.36.

STEP 2: After successful setting of the product count, a message ‘Set Product count success’ will appear in the text view as shown in figure 2.35.

NOTE: If we provide 9,999,999 as the product count, product count is set as infinity. Maximum product count that can be set is 5,000,000.

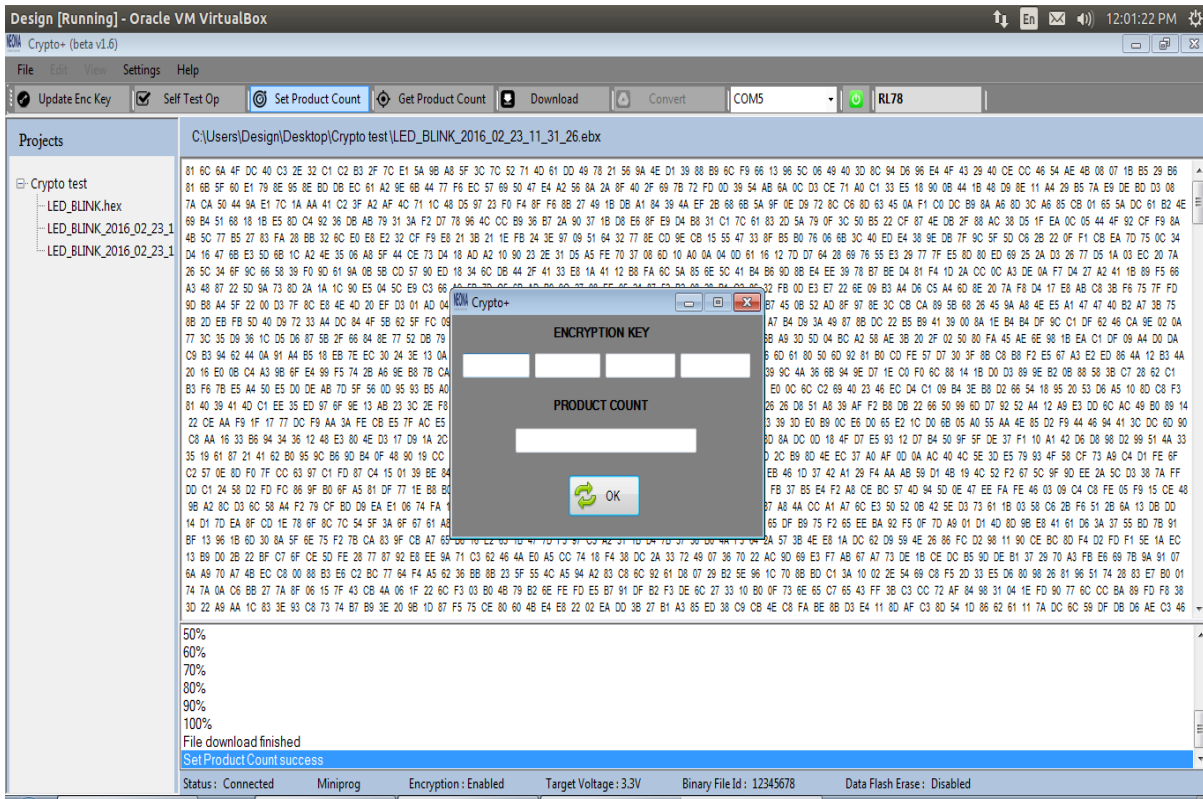

Figure 2.36

2.3.8 Get Product Count

STEP 1: Click on the **Get Product Count** in the Tool-Strip as shown in figure 2.37.

STEP 2: A message **‘Getting Product count successful’** and the product count value is displayed in the text view as shown in figure 2.37.

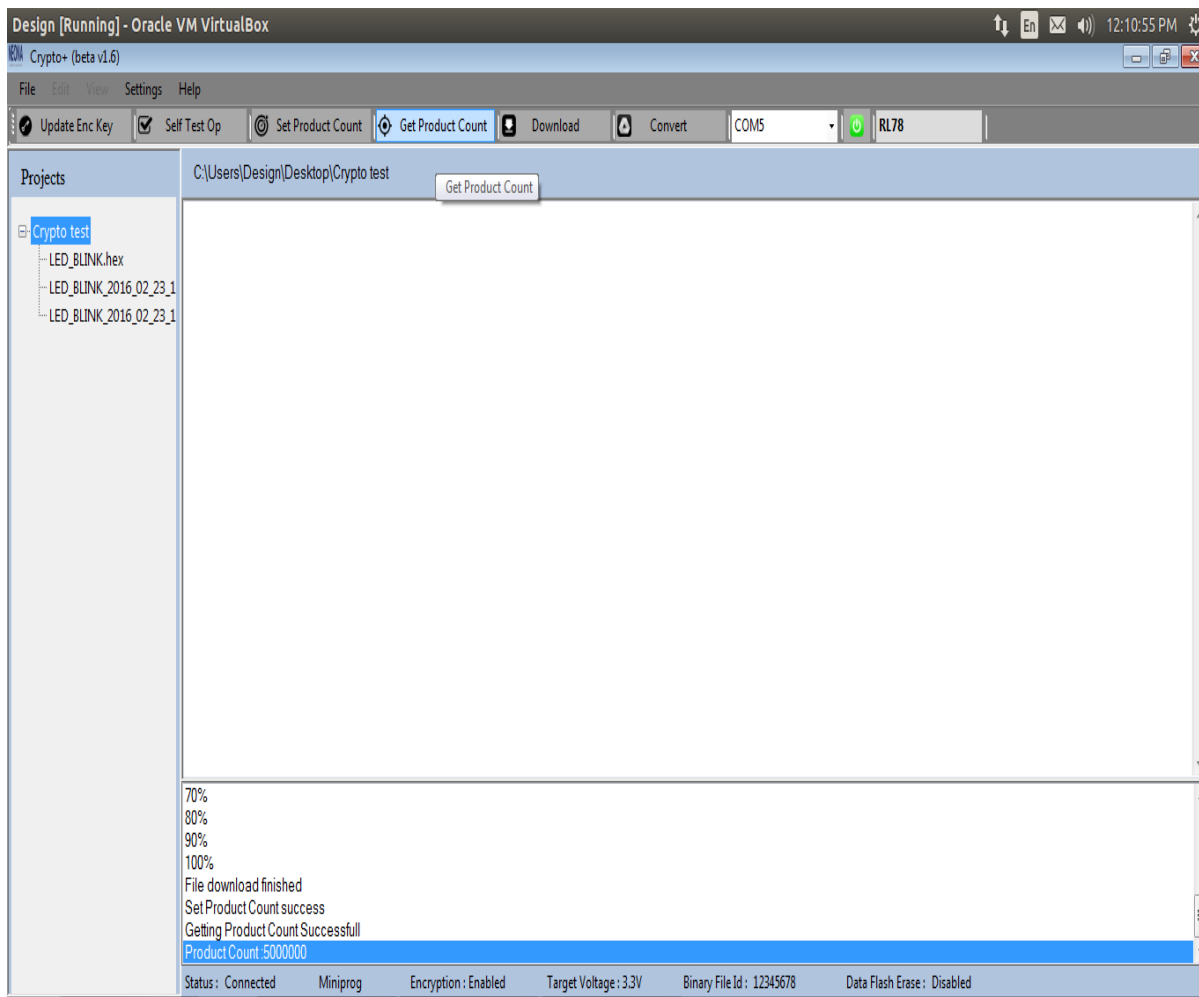

Figure 2.37

2.3.9 Self Test Op

The status of all targets can be checked using the Self Test Op.

STEP 1: Remove all the targets board connections from Programmer

STEP 2: Click on **Self Test Op** as shown in figure 2.38.

STEP 3: Each target's status will appear in text view as shown in figure 2.38.

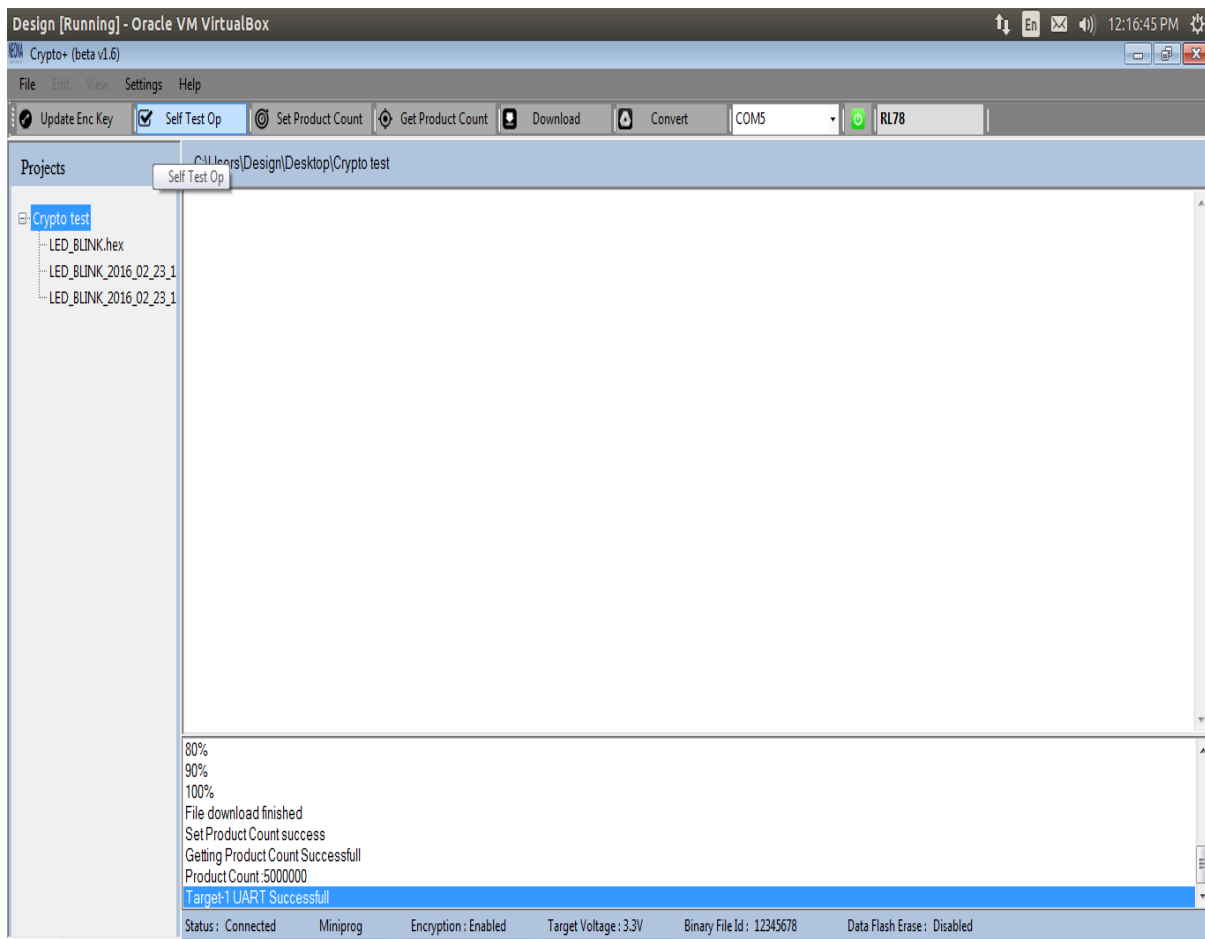

Figure 2.38

2.3.10 Update Encryption Key

STEP 1: Click on **Update Enc Key** as shown in figure 2.39.

STEP 2: Enter current encryption key & new encryption key & click **OK**.

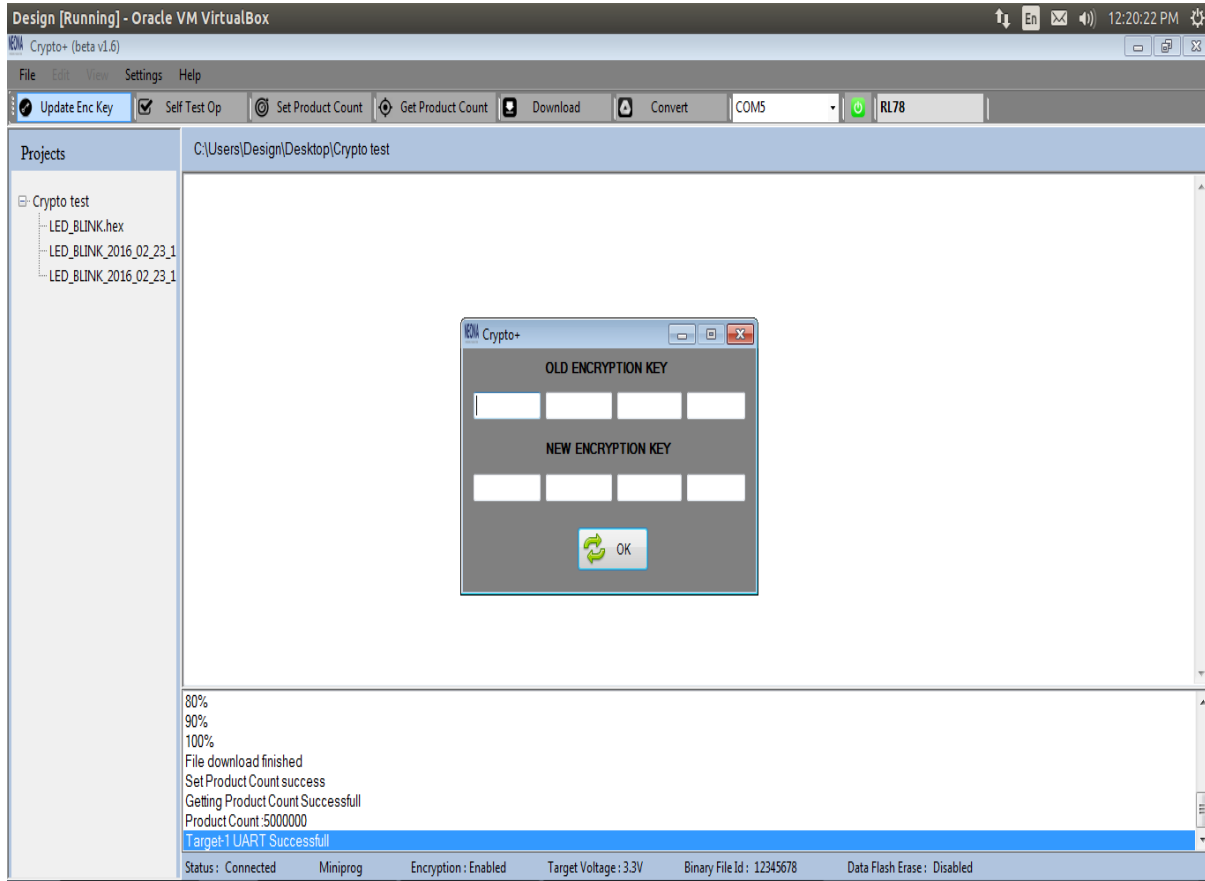

Figure 2.39

STEP 3: A message ‘**Encryption key Updated successfully**’ is displayed in the text view as shown in figure 2.40.

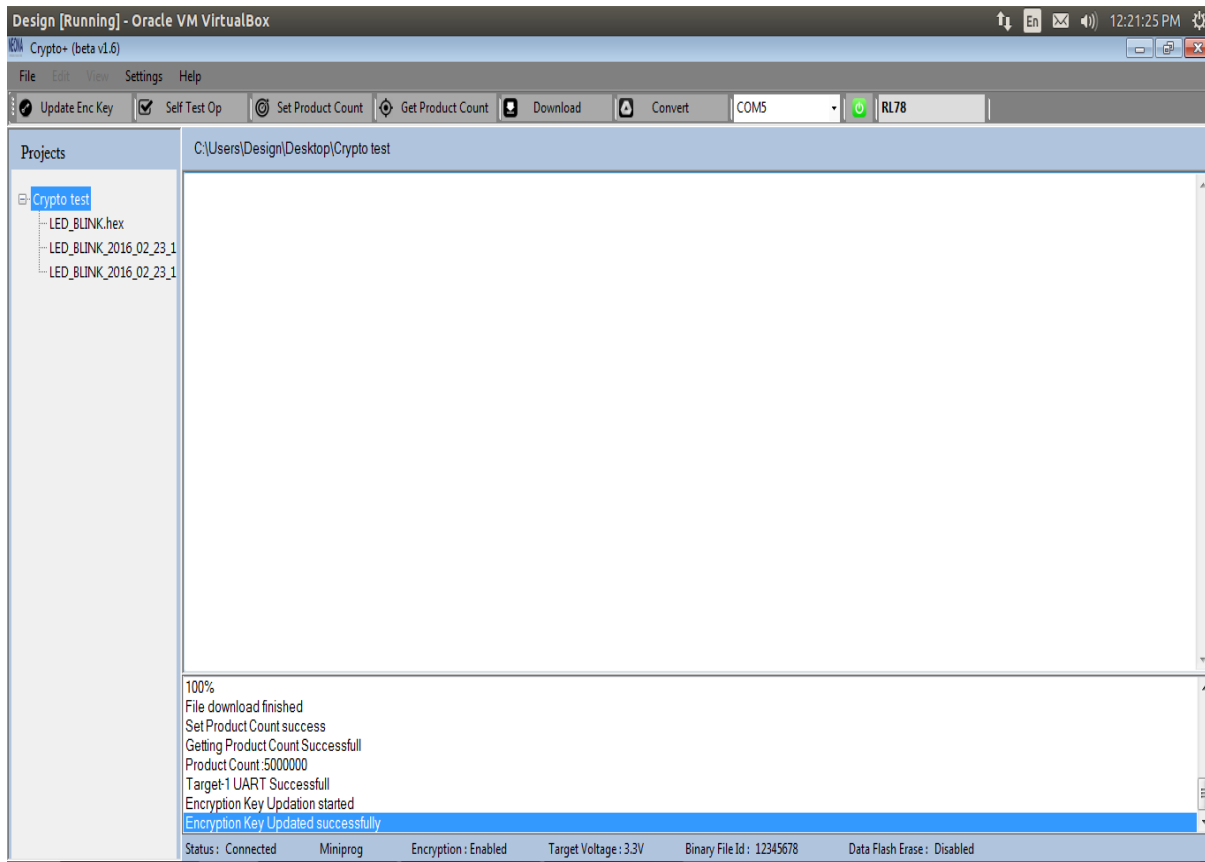



Figure 2.40

2.3.11 Restore Factory Settings

Programmer will be reset to factory setup. The program and target count will be erased & encryption key is set to default encryption key which is set by the manufacturer.

STEP 1: Connect to the device. Press 

STEP 2: Click **Restore Factory Settings** option in Help shown in figure 2.41.

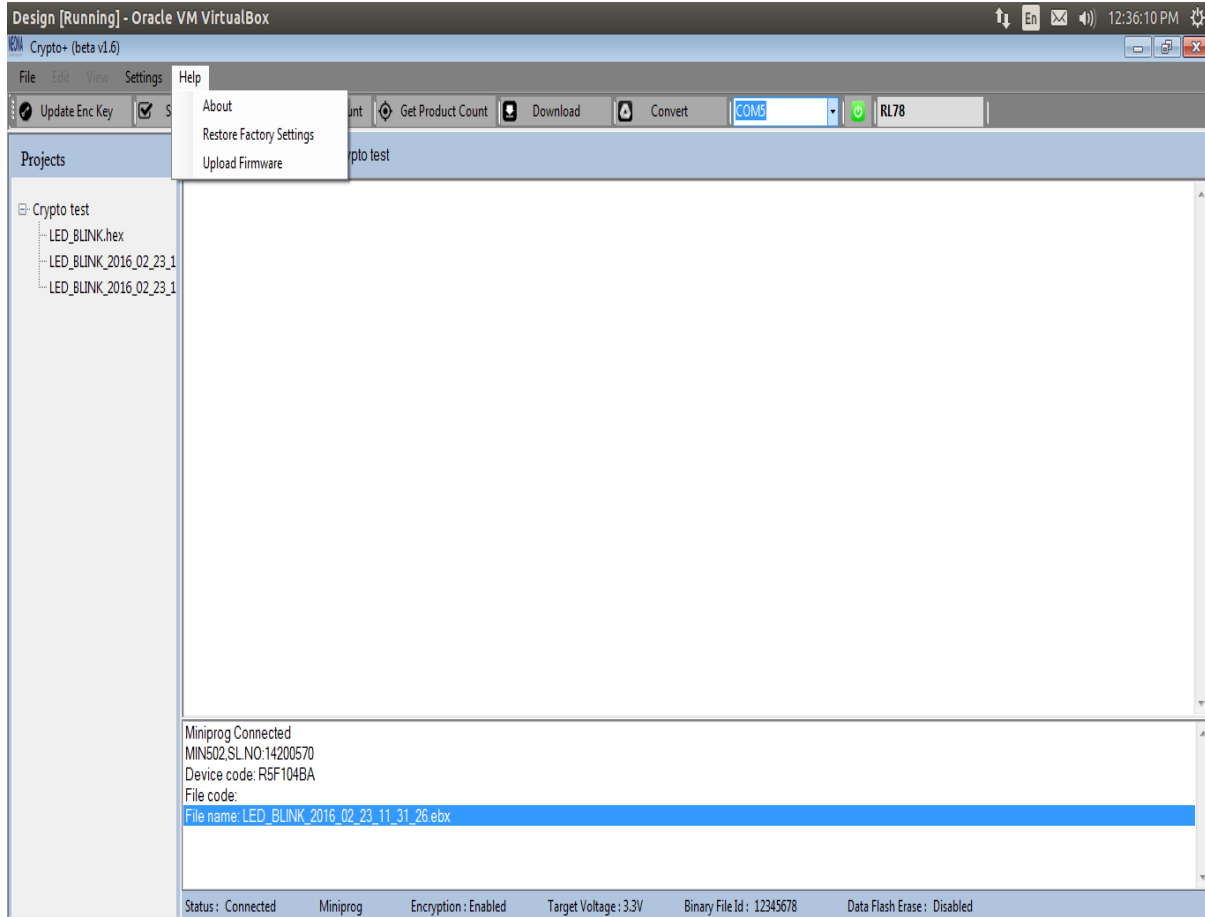

Figure 2.41

STEP 3: A dialog box asking for confirmation will appear as shown in figure 2.43. Click **Yes** to proceed.

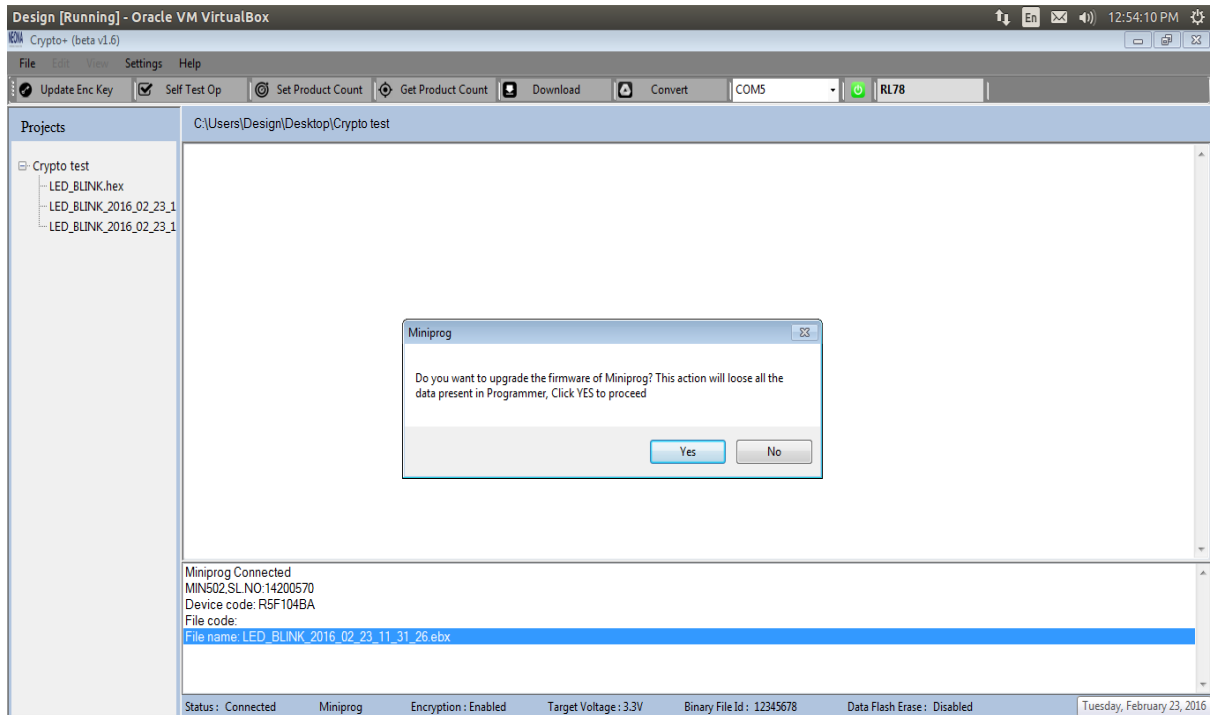

Figure 2.43

STEP 5: Select the .octfrm firmware file from the Open window.

STEP 6: Click **open**.

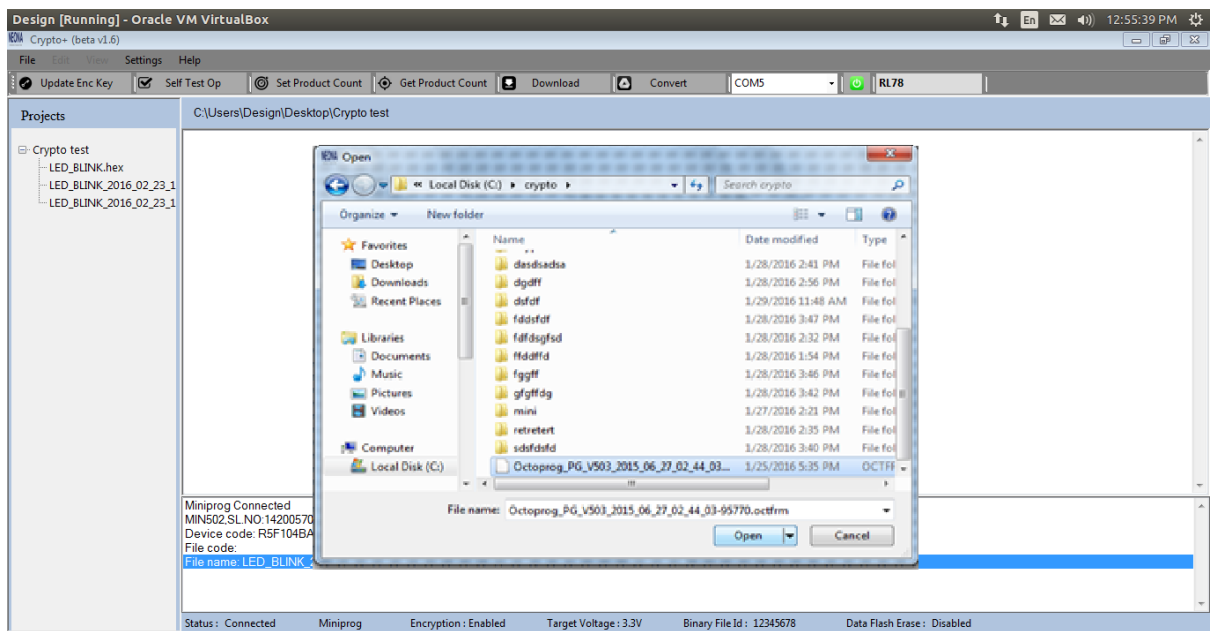

Figure 2.44

STEP 7: After completing firmware download, message **'Firmware File download finished'** will be displayed in the text view as shown in figure 2.45.

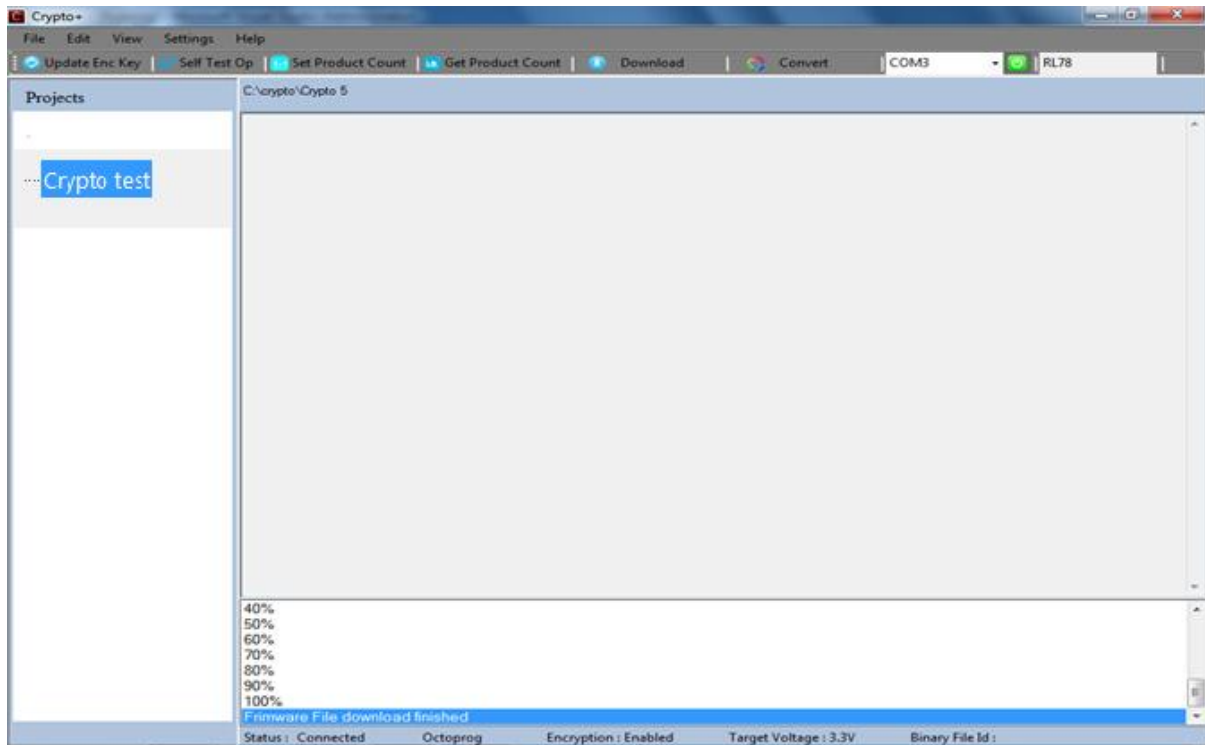

Figure 2.45

2.3.13 About Us

STEP 1: Click **About** option in Help shown in figure 2.41.

STEP 2: A window ‘**About Us**’ as shown in figure 2.46 will appear, which shows the details about the Crypto+.

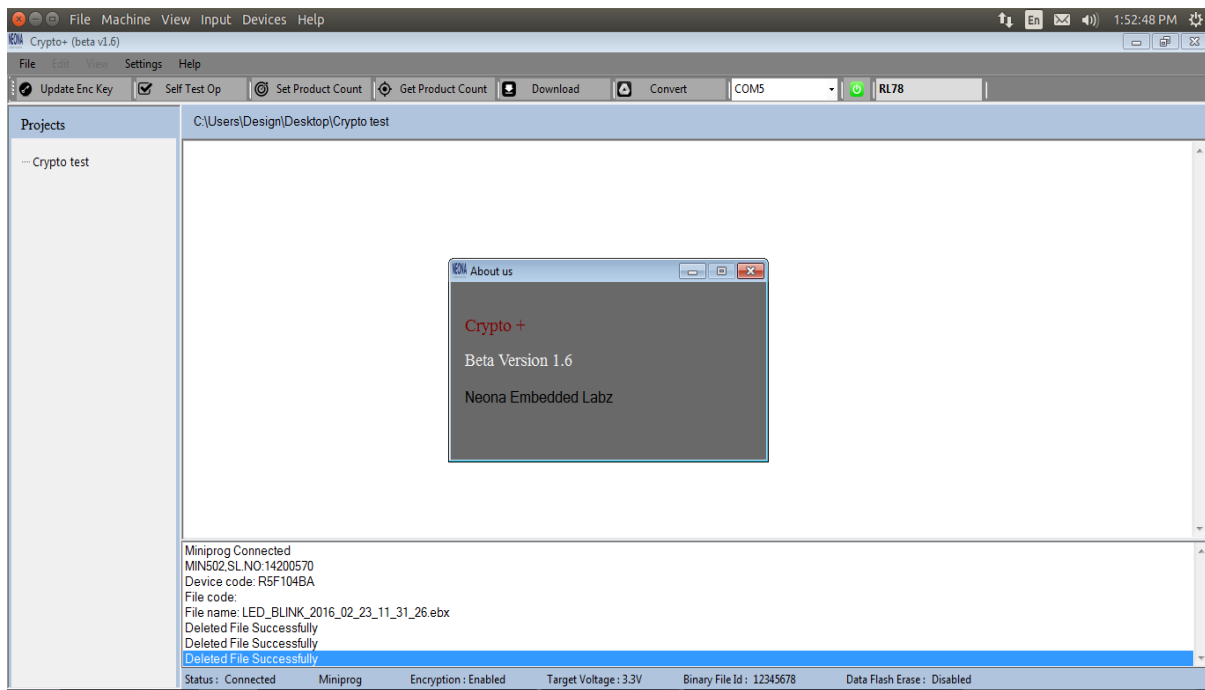

Figure 2.46

2.3.14 Settings

There is a Settings menu in Crypto+ in which various settings can be changed. Clicking on Settings will show all options in the settings menu as shown in figure 2.47. The options are as follows:

- **Enable encryption:** Encryption status can be enabled or disabled. It depends on device and programmer that you have selected.
- **5V:** Target power can be changed to 5V. 5V option is available depending on the chosen device and programmer.
- **Data Flash Erase:** Data Flash erase can be enabled or disabled.
- **Set Binary File Id:** Provide option to set Binary file id
- **Programmer:** Helps to select the required programmer.

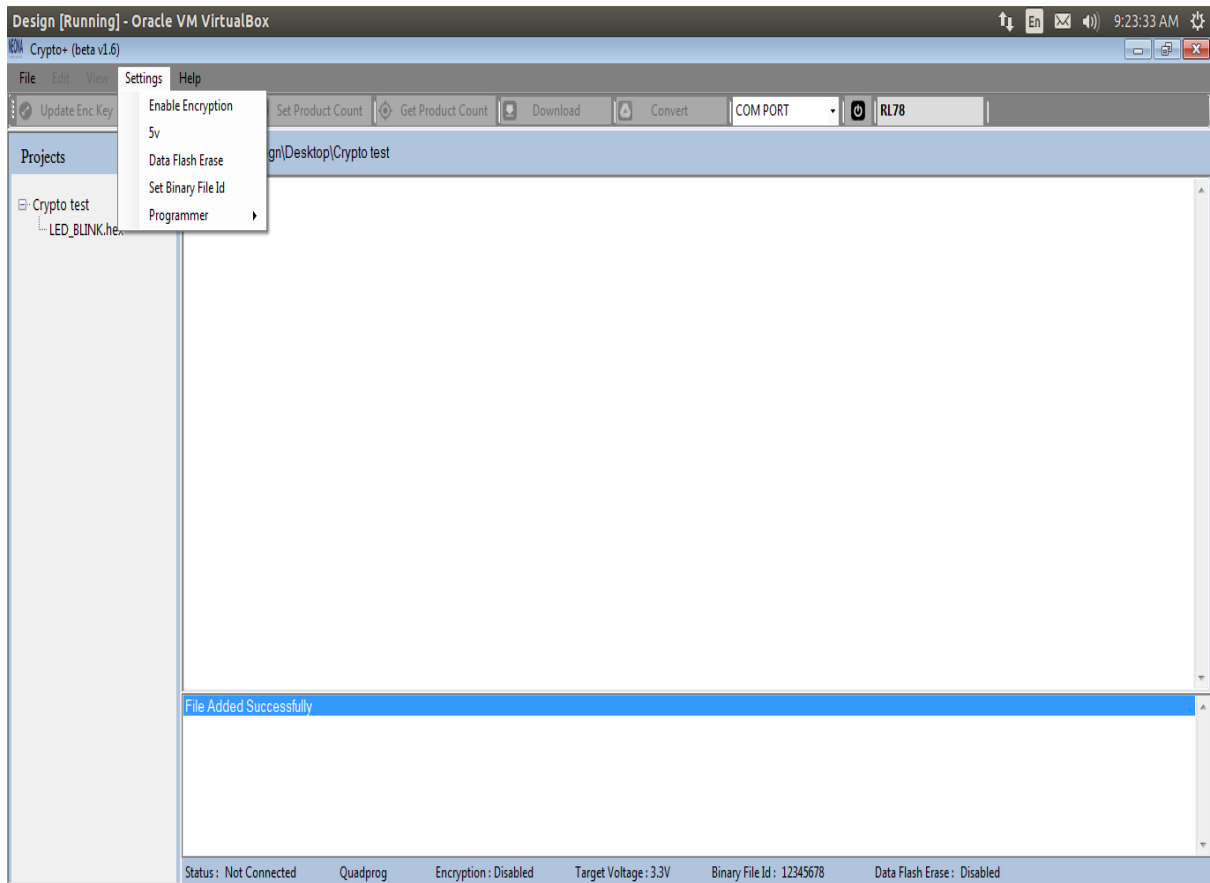

Figure 2.47

NOTE: Details about the above mentioned settings is described in detail in Section 2.3.1.

2.3.15 File

The options available when clicking File button is shown in figure 2. 48.

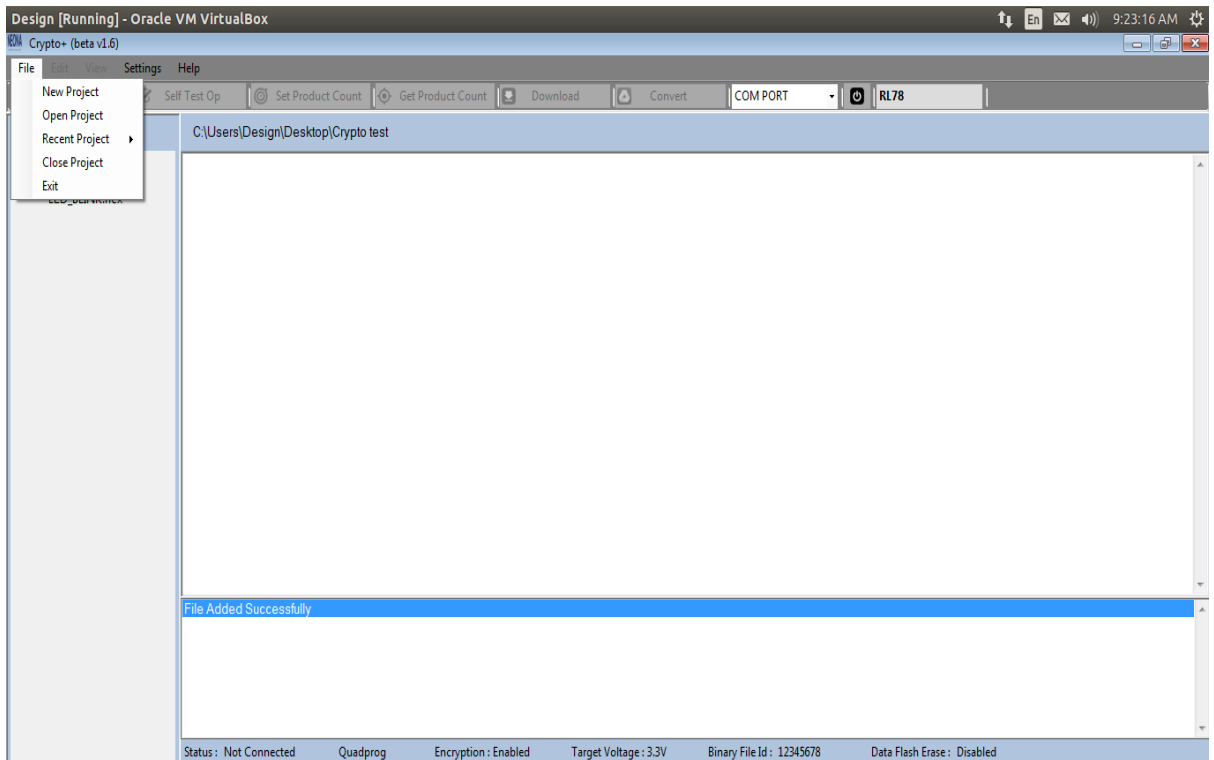

Figure 2.48

- **New Project:** A new project can be created with this option. Follow the steps starting from STEP 2 in section 2.3.1 to create new project.
- **Open Project:** A project can be opened with this option. Follow the steps starting from STEP 2 in section 2.3.2 to open a project.
- **Recent Project:** Helps to open recently opened projects.
- **Close Project:** The current project can be closed using the Close Project option.
- **Exit:** To exit from the application click Exit option.

2.3.16 Project options

Different project options can be seen when we right click on the project name in the tree-view as shown in figure 2.49.

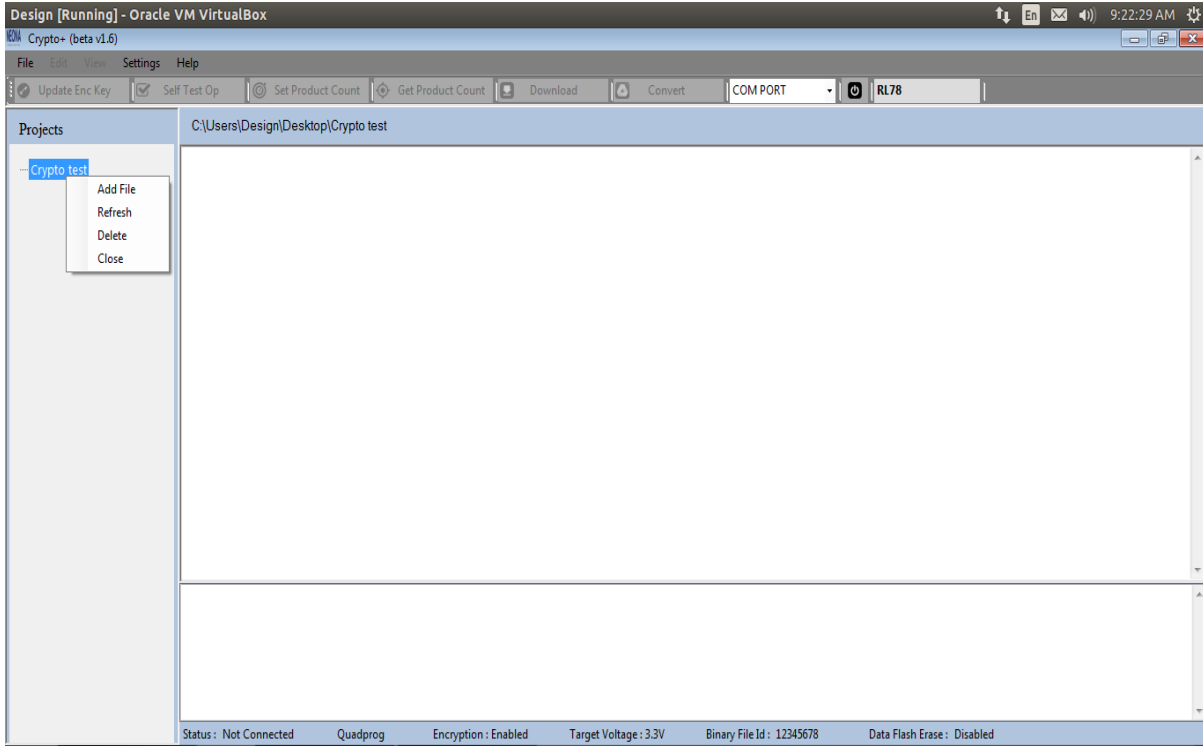

Figure 2.49

- **Add file:** Refer section 2.3.3.
- **Refresh:** The project can be refreshed using this option.

- **Delete:** The project can be deleted. A warning window will appear as shown in figure 2.50. If you want to proceed then click **Yes**. After deleting the project a message **‘Deleted Project Successfully’** will appear in the text view.

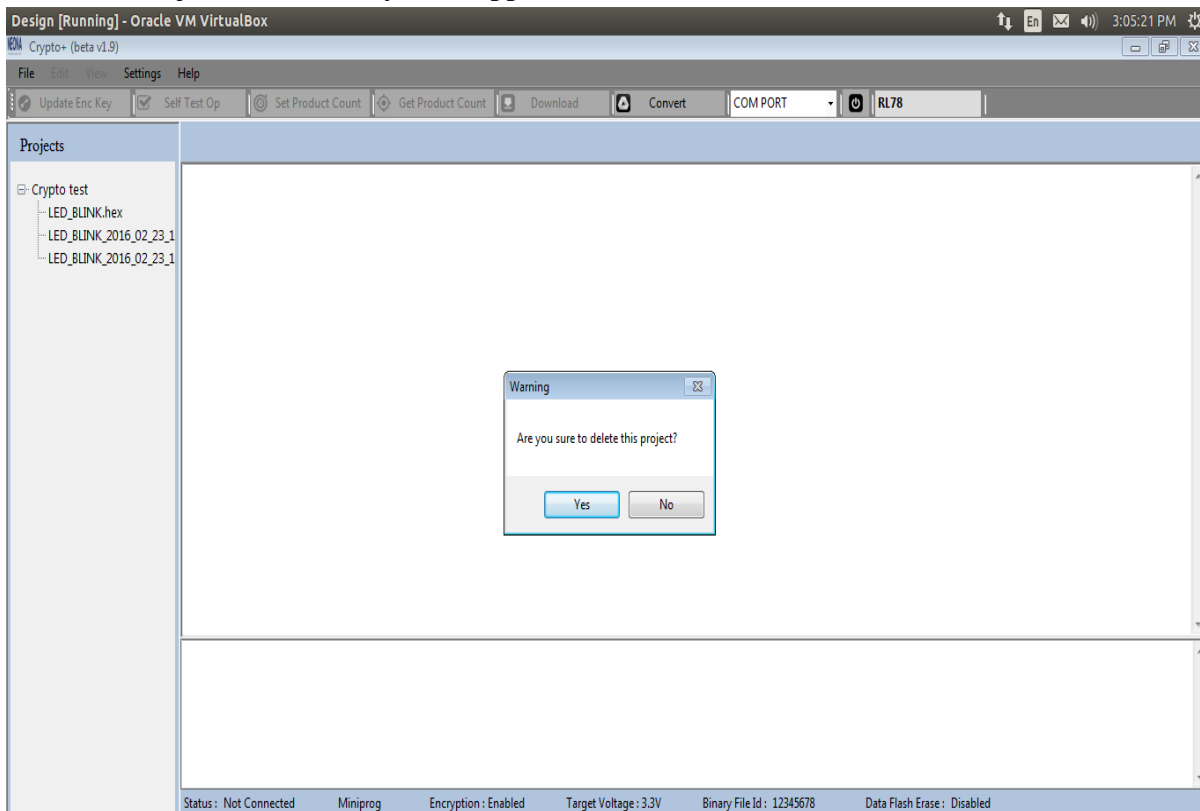

Figure 2.50

- **Close:** The project can be closed using this option.

2.3.17 Delete File in a Project

- **STEP 1:** Right click on the file to be deleted & select **Delete**.

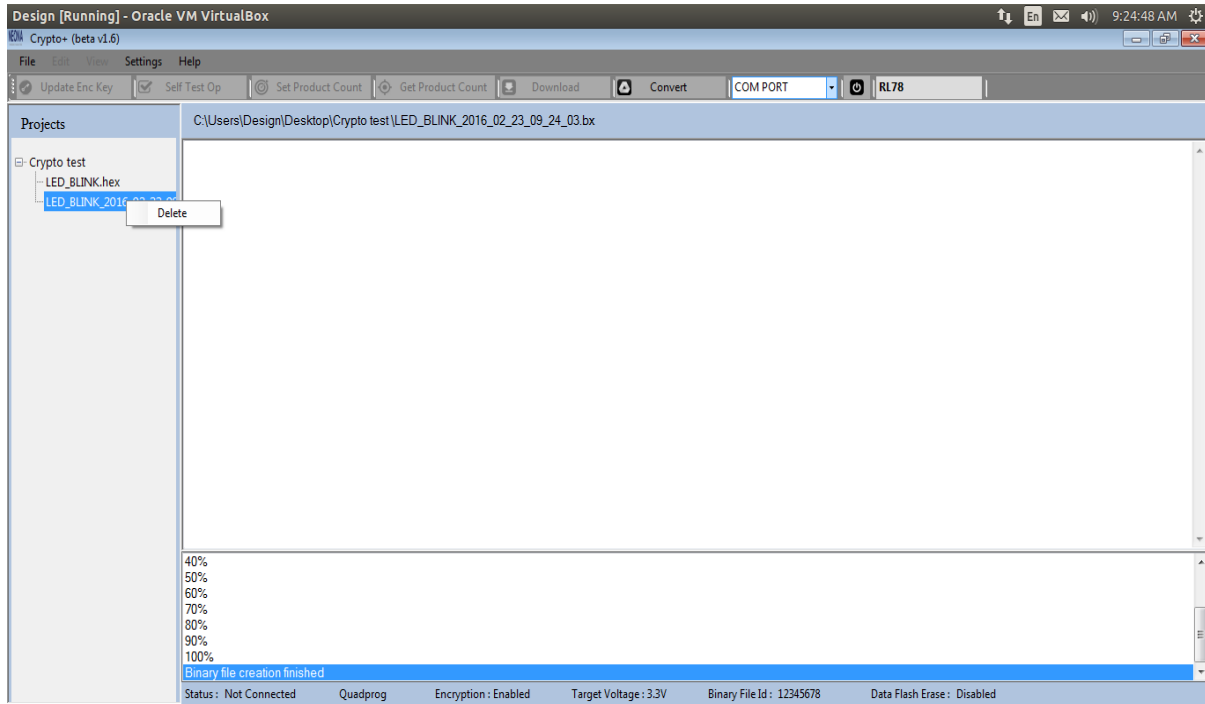

Figure 2.51

- **STEP 2:** A warning window will appear as shown in figure 2.52. If you want to proceed then click **Yes**. If the file is deleted successfully then a message ‘Deleted file Successfully’ will be shown in the text view.

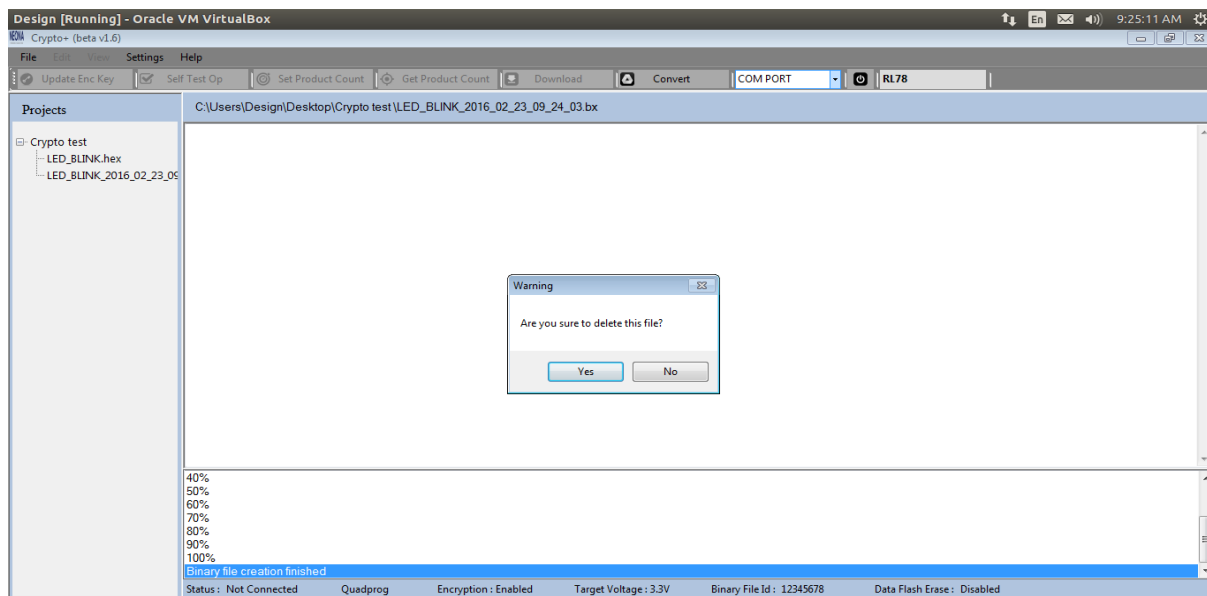

Figure 2.52

2.4 Download program to target devices(Stand Alone Programming Steps):

1. Switch on the Octoprog device using 5v, 3A adapter & connect the targets to the Octoprog.
2. Press the **START** button for about 2 seconds to start flashing the connected targets. When the Octoprog is flashing the targets, corresponding target LEDs will be blue.
3. If flashing is completed successfully, corresponding target LEDs turns green.
4. If there is a failure in flashing, corresponding target LED will turn red.
5. After the target programming is completed, reset the Octoprog by using **START** switch.
6. The target count will be decremented after each successful flashing. When target count becomes zero, the program downloaded to Octoprog will be erased instantly. After that, if you try to download the program to target device, all LEDs will glow white indicating no program is downloaded to Octoprog. You can check the current target count in USB_MODE.

2.5 LED INDICATIONS:

When Octoprog is got into USB_MODE, all the LEDs blink once.

LED indications in USB_MODE.

1. When Octoprog software is connected to the device properly, T5 glows green.
2. When download ENC hex is success, following LED indications are there:
 1. Erasing success, T6 glows green
 2. Programming success, T7 glows green
 3. Successfully stored device information, T8 led glows green
3. Update encryption key success, T4 glows green.
4. Set product count success, T2 glows green.
5. Restore factory set up command processing, T5 led glows blue. Restore factory set up success, T3 glows green.

When Octoprog is got into PROGRAM_MODE, all led's blink once red, once blue & once green.

LED indications in PROGRAM_MODE after START button is pressed for programming the target device,

1. If there is no target program is downloaded or target product count is not set or your target count limit is reached(i.e. when you reach the target count limit, the target program downloaded to RX will be erased & will be in no program downloaded condition), all the LEDs glow white.
2. When programming is progressing corresponding target's blue led will be glowing.
3. When programming is failed, corresponding target's red led will be glowing.
4. When block programming is success, corresponding led will blink green.
5. When block verification is success (i.e. programming is completed successfully), corresponding target's green led will be glowing.

